



**Technical Service  
BULLETIN**

March 19, 2004

Title:

**WINDSHIELD MOLDING DEFORMATION**

Models:

'03 – '04 4Runner



REVISED  
B0005-04  
BODY

**TSB REVISION NOTICE:**

**April 28, 2004:** A note has been added to step 4 on page 3 to clarify the removal of the roof rack. All previous versions of this TSB should be discarded.

**Introduction** Some 2003 – 2004 model year 4Runner vehicles may experience windshield moldings that have warped or lifted. Replace windshield moldings with a new service part to correct the condition.

- Applicable Vehicles**
- **2003 – 2004** model year **4Runner** vehicles produced **BEFORE** the Production Change Effective VINs shown below.

**Production Change Information**

MODEL	ENGINE	DRIVETRAIN	PLANT	PRODUCTION CHANGE EFFECTIVE VIN
4Runner	6 Cylinder	2WD	Tahara	JTEZU14R*40018362
			Hino	JTEBU14R*48009540
		4WD	Tahara	JTEBU14R*40021509
			Hino	JTEBU14R*48011282
	8 Cylinder	2WD	Tahara	JTEZT14R*40014074
			Hino	JTEZT14R*48002948
		4WD	Tahara	JTEBT14R*40028472
			Hino	JTEBT17R*48008587

**Warranty Information**

OP CODE	DESCRIPTION	TIME	OFF	T1	T2
BD3022	R & R Windshield Outside Molding, LH (with roof rack)	0.8	7553#--350#0	62	15
Combo A	R & R Windshield Outside Molding, RH (with roof rack)	0.8			
BD3023	R & R Windshield Outside Molding, LH (without roof rack)	0.4			
Combo A	R & R Windshield Outside Molding, RH (without roof rack)	0.4			

**Applicable Warranty\*:**

**This repair is covered under the Toyota Comprehensive Warranty. This warranty is in effect for 36 months or 36,000 miles, whichever occurs first, from the vehicle's in-service date.**

\* Warranty application is limited to correction of a problem based upon a customer's specific complaint.

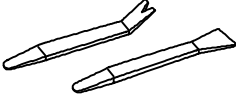

**Required SSTs**

SPECIAL SERVICE TOOLS (SSTs)		PART NUMBER	QUANTITY
Plastic Pry Tool Set*		00002-06000-01	1

\* Essential SSTs.

**NOTE:**  
**Additional SSTs may be ordered by calling SPX/OTC at 1-800-933-8335.**

**Required Tools & Material**

TOOLS & MATERIAL	PART NUMBER	QUANTITY
3M™ General Purpose Adhesive Cleaner*	3M 08984	Six 1 quart cans
Loc-Tite® Permanent Strength Thread Locker**	Loc-Tite 26231, red	50 mm bottle

\* Contact 3M at 1-877-666-2277 for product availability.

\*\* Contact Loc-Tite at 1-800-562-8483 for product availability.

**Parts Information**

PREVIOUS PART NUMBER	CURRENT PART NUMBER	PART NAME	QTY
75533-35040	Same	Molding, Windshield Outside, RH	1
75534-35010	Same	Molding, Windshield Outside, LH	1
63437-60020	Same	Seal	8

**4Runner with Roof Rack Repair Procedure**

For further information, refer to the Technical Information System (TIS): 2003 or 2004 model year 4Runner Repair Manual: *Exterior/Interior Trim: Roof Drip Side Finish Moulding LH.*

1. Remove the roof rack assembly.
2. Remove the front roof rack leg cover.
  - A. Using a screwdriver, disengage the four claws and clip that secure the leg cover to the roof rack end support leg.

**NOTE:**  
**Tape the screwdriver tip before use to help prevent vehicle damage.**

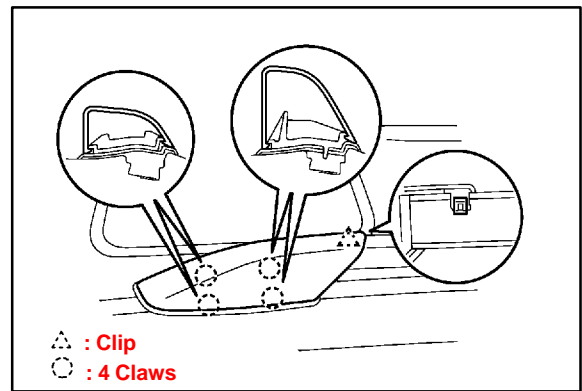

#### 4Runner with Roof Rack Repair Procedure (Continued)

3. Repeat step 2 for each of the remaining three leg covers.
4. Remove the eight bolts that secure the roof rack legs to the roof.

**NOTE:**

To help prevent nut plate from disengaging and coming loose from the roof assembly, remove bolts identified with a “1” first, then remove bolts identified with a “2.”

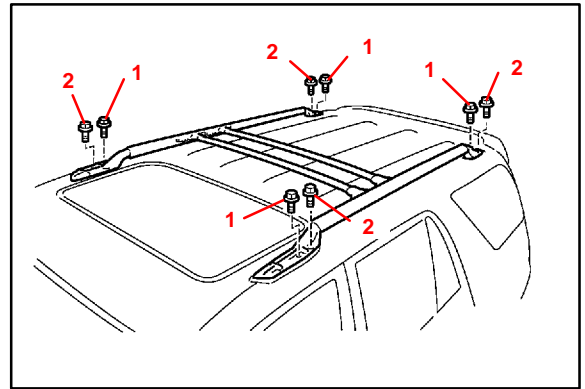

5. Using a torx wrench (T25), remove the eight bolts from the underside of the right and left side roof rack cross bar joints. Remove roof rack assembly from vehicle roof.
6. Remove front fender to cowl side seal.
  - A. The fender to cowl side seal is held in place with a clip and two claws.
  - B. With the hood open, use the SST plastic pry tool to pry the side seal loose.
    - SST P/N 00002-06000-01
  - C. Remove the fender to cowl side seal.
7. Remove windshield molding.
  - A. Starting at the base of the windshield, carefully pull the windshield molding out by hand.

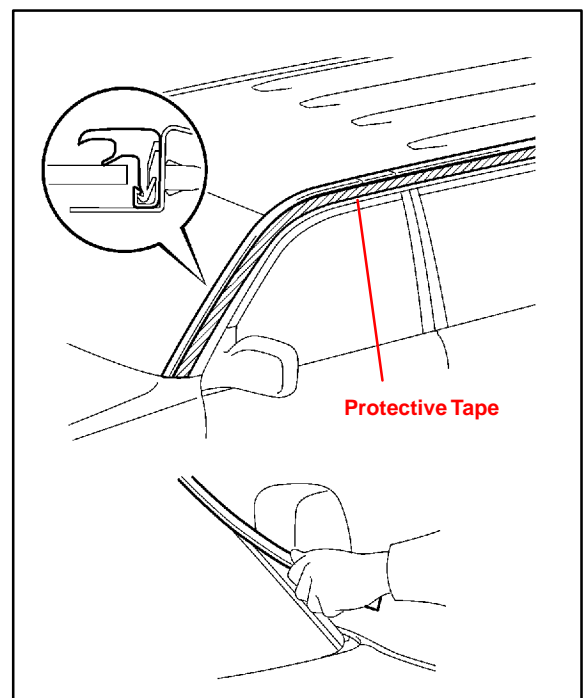
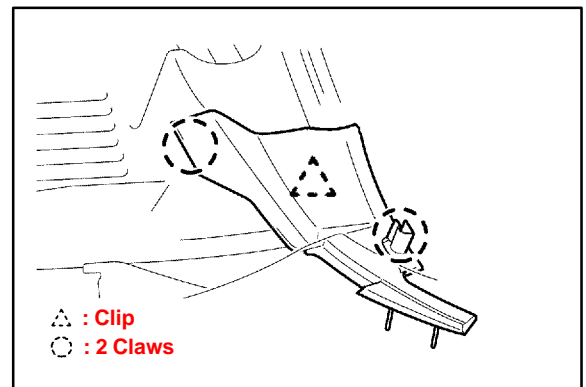

**4Runner with  
Roof Rack  
Repair  
Procedure  
(Continued)**

8. Thoroughly clean the roof rail with 3M™ General Purpose Adhesive Cleaner (3M™ P/N 08984) to ensure proper adhesion of the new windshield molding.

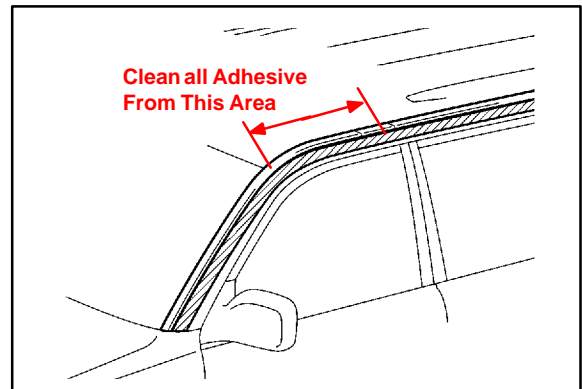

9. Install outside windshield molding No. 1.
- Install the middle of the molding securely against the upper windshield molding as shown in the illustration.
  - Remove the backing from each of the two areas of adhesive tape and install the rear end of the molding to the roof.
  - Install the front end of the molding along the side of the windshield.
10. Reinstall the front fender to cowl side seal.
11. Reinstall the roof rack assembly in reverse order of removal.
- Using 3M™ General Purpose Adhesive Cleaner (3M™ P/N 08984), clean the adhesive from the bolts and threads.

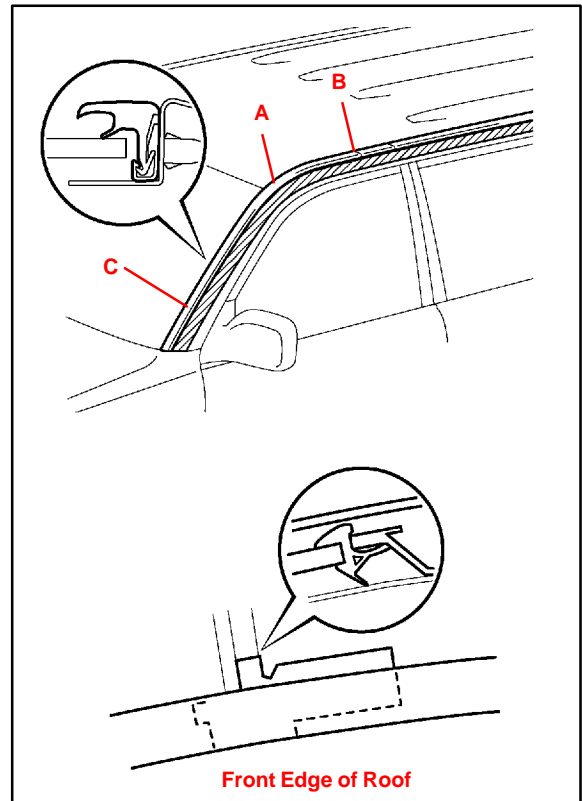

- Apply Loc-Tite® Permanent Strength Thread Locker (Loc-Tite® P/N Loc-Tite 26231) to the last two or three threads at the bolt end.

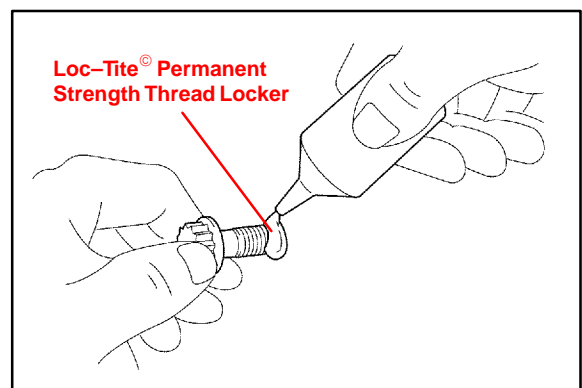

**4Runner with  
Roof Rack  
Repair  
Procedure  
(Continued)**

12. Install the right and left roof rack assembly with the eight bolts.

**Torque: 7.4 ft•lbf (10.0 N•m, 102 kgf•cm)**

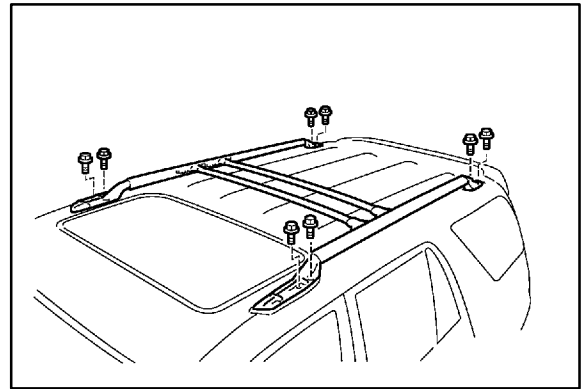

**NOTE:**

Use new seals (P/N 63437-60020) for each of the eight roof rack assembly bolts.

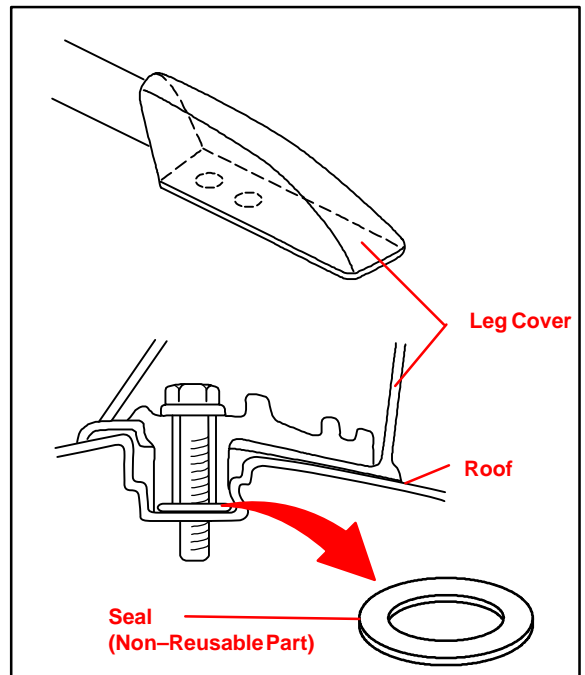

**4Runner  
without Roof  
Rack Repair  
Procedure**

1. Remove front roof drip side molding end cover.
  - A. Using a screwdriver, disengage the two claws and remove the molding end cover.

**NOTE:**

**Tape the screwdriver tip before use to help prevent vehicle damage.**

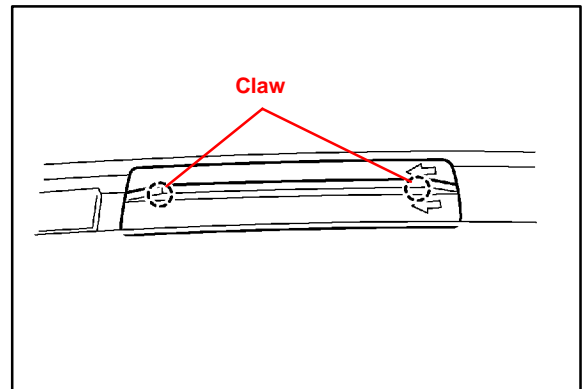

2. Remove front fender to cowl side seal.
  - A. The fender to cowl side seal is held in place with a clip and two claws.
  - B. With the hood open, use a plastic pry tool to pry the side seal loose.
    - SST P/N 00002-06000-01
  - C. Remove the fender to cowl side seal.

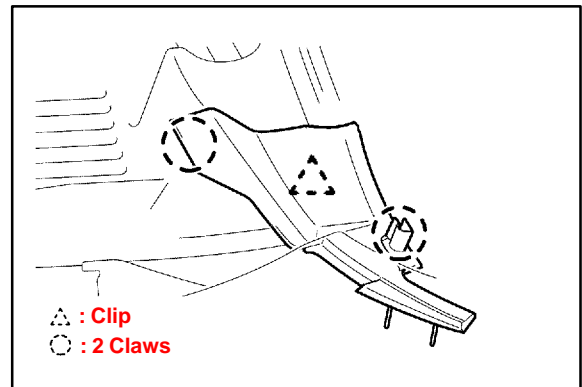

3. Remove windshield molding.
  - A. Starting at the base of the windshield, carefully pull the windshield molding out by hand.

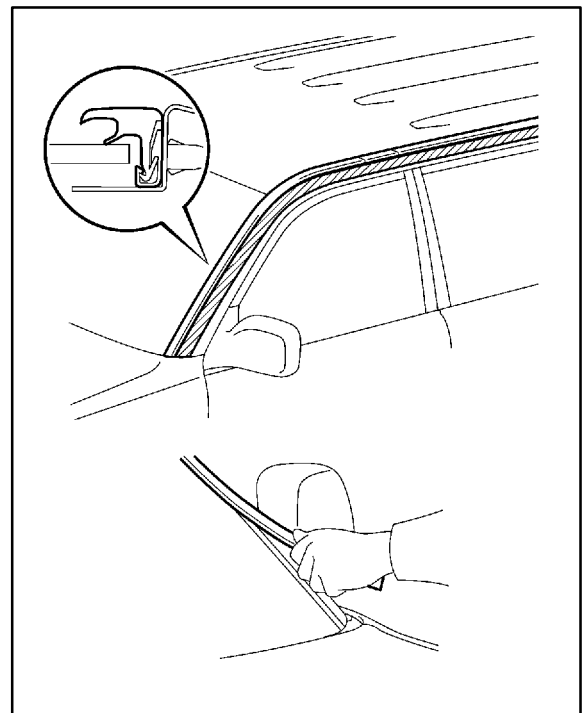

**4Runner  
without Roof  
Rack Repair  
Procedure  
(Continued)**

4. Thoroughly clean the exposed metal roof rail as shown to the right with 3M™ General Purpose Adhesive Cleaner (3M™ P/N 08984) to ensure proper adhesion of the new windshield molding.

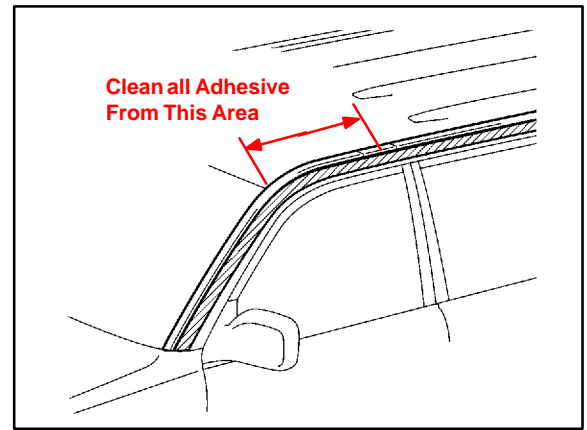

5. Install outside windshield molding No. 1.
- Install the middle of the molding securely against the upper windshield molding as shown in the illustration.
  - Remove the backing from each of the 2 areas of adhesive tape and install the rear end of the molding to the roof.
  - Install the front end of the molding along the side of the windshield.
6. Reinstall the front fender to cowl side seal.
7. Reinstall the roof front drip side molding end cover.

