

TOYOTA

SERVICE BULLETIN

TOYOTA MOTOR SALES, U.S.A., INC.

VOLUME

9

HEATING AND
AIR CONDITIONING

REFERENCE NUMBER _____
DATE _____
MODEL _____

004
01-08-88
FX, MR2

Page 1 of 1

VSV COMPONENTS IN A/C KITS

The VSV (Vacuum Switching Valve) in the A/C kits (P/N 00883-17880) MR2 and (P/N 00883-02870) FX-16 are not required on 1988 MR2 and FX-16.

The vacuum switching valve has been installed at the factory for 1988 models. The 1987 vehicles did not have the VSV installed at the factory.

The following illustrations indicate the affected VSV:

MR2
(P/N 88609-17010)
VSV

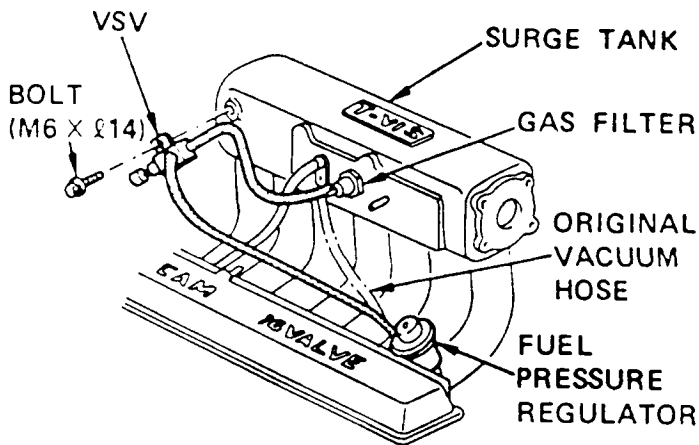

FX-16
(P/N 90081-91002)
VSV

