



# Technical Service BULLETIN

January 12, 2005

## Title: TOWING RECEIVER HITCH WELD STUD Models: '04 – '05 Highlander

AX001-05 ACCESSORIES

**Introduction** The weld stud on the 2004 and 2005 model year Highlander towing receiver hitch accessory bracket torque specification has changed.

- Applicable Vehicles**
- **2004 – 2005** model year **Highlander** vehicles equipped with **Accessory Towing Receiver Hitch**.

### Parts Information

PREVIOUS PART NUMBER	CURRENT PART NUMBER	PART NAME	QTY
PT228-69045	Same	Towing Receiver Hitch	1

### Required Tools & Material

TOOLS & MATERIAL	QUANTITY
Socket Wrench with 4" & 6" Extensions	1 Each
Sockets: 14 mm, 15 mm	1 Each
Torque Wrench (N•m, ft•lbf)	1

### Repair Procedure

Install nut to the following torque specification.

**Torque: 36 N•m (27 ft•lbf)**

Please use the revised torque specification (36 N•m [27 ft•lbf]) for this fastener (see illustration). Please refer to the installation instructions for the remaining fastener torque values.

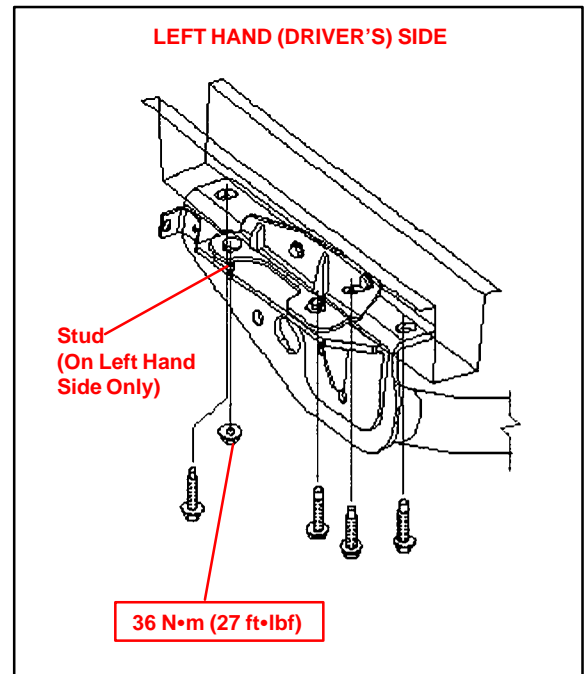

### Warranty Information

OP CODE	DESCRIPTION	TIME	OFF	T1	T2
N/A	Not Applicable to Warranty	–	–	–	–

