



**Technical Service
BULLETIN**

March 12, 1999

Title:

**TOWING HITCH INSTALLATION
INSTRUCTION AMENDMENT**

Models:

'99 Land Cruiser

AX003-99
ACCESSORIES

Introduction The '99 Land Cruiser is equipped with a Rear Bumper Fascia Reinforcement which interferes with the clearances around the Toyota Towing Hitch. Remove the Bumper Reinforcement and discard before installing the Towing Hitch.

Affected Vehicles • **1999 Land Cruiser**

Removal Procedure

1. Locate the Reinforcement at the rear of the vehicle (See Illustration).
2. Remove the 6 attachment bolts (size 12 mm x 8 mm x 1.25).
3. Remove the 2 plastic fasteners, release by a 1/4 turn of a Phillips screwdriver.
4. After removing the hardware, slightly bend the two tabs that are part of the Bumper Fascia to allow the reinforcement to be removed.
5. Once the reinforcement is removed and the hitch is installed, four of the 12 mm bolts are reinstalled (2 Outboard & 2 Inboard.)
6. Two bolts and two Plastic Fasteners are discarded along with the reinforcement.
7. Removal time should be about 60 seconds, less for two installers. You may also need to pull the Muffler Pipe slightly to the side while positioning the hitch.

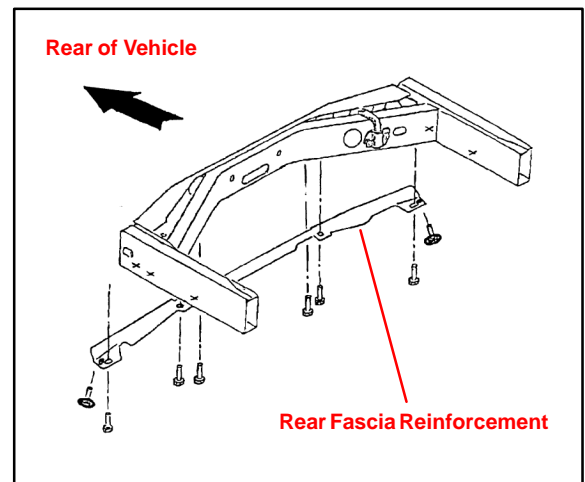

Warranty Information

| OP CODE | DESCRIPTION | TIME | OPN | T1 | T2 |
|---------|----------------------------|------|-----|----|----|
| N/A | Not Applicable to Warranty | - | - | - | - |

