

Short Pin Installation During PDS

Service Category General

Section Pre-Delivery Service

Market USA

Toyota Supports
 ASE Certification 

Applicability

YEAR(S)	MODEL(S)	ADDITIONAL INFORMATION
2009	FJ Cruiser	

Introduction

To minimize battery discharge during transportation and storage, the Short Pin has been removed at the assembly plant and temporarily stored in the engine compartment Relay Block. Reinstall the Short Pin into its original location and confirm all related DTCs are cleared during Pre-Delivery Service (PDS).

Required Tools & Equipment

REQUIRED EQUIPMENT	SUPPLIER	PART NUMBER	QTY
TIS Techstream* NOTE: Software version 3.01.000 or later is required.	ADE	TSPKG1	1

* Essential SST.

NOTE

Additional TIS Techstream units may be ordered by calling Approved Dealer Equipment (ADE) at 1-800-368-6787.

Warranty Information

OP CODE	DESCRIPTION	TIME	OFF	T1	T2
N/A	Not Applicable to Warranty	–	–	–	–

Short Pin Installation During PDS

Installation Procedure

The Short Pin is stored in the blank space of the Relay Block in the engine compartment. During Pre-Delivery Service (PDS), install the Short Pin in the Relay Block as shown.

Figure 1.

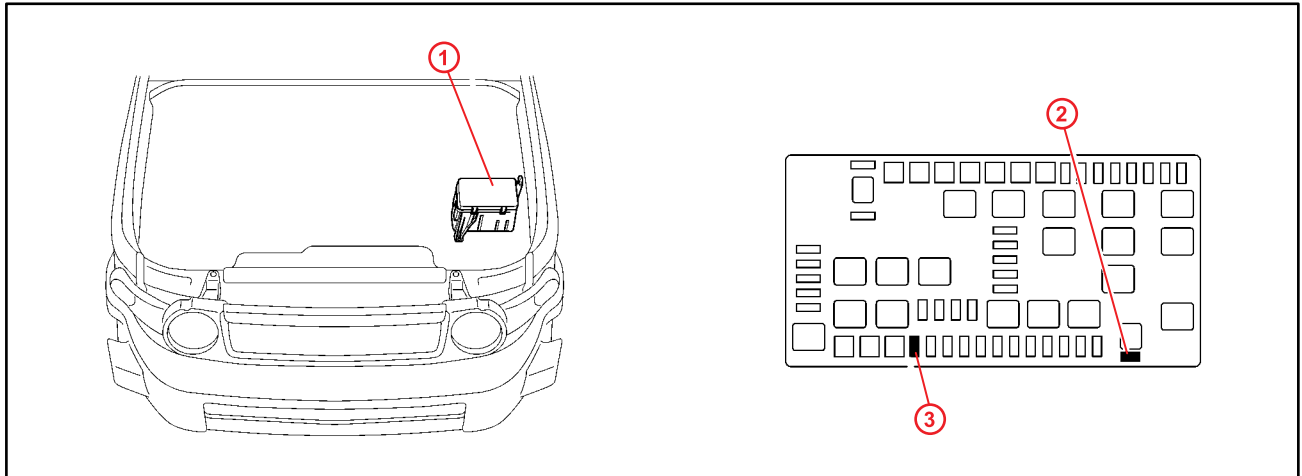

1	Relay Block
2	Remove This Short Pin

3	Install Short Pin Here (Original Location)
----------	--

NOTE

- Removing the Short Pin cuts off power sources relating to the DOME, RADIO No. 1, and ECU-B fuses.
- The Short Pin does NOT function as a fuse, so install it only in the position shown above.
- If the vehicle is stored at the dealership after PDS, disconnect the negative (-) battery terminal to prevent battery discharge. Refer to TSB No. [PG001-06](#), "Battery Maintenance for In-Stock Vehicles & Pre-Delivery," for battery maintenance information.

DTC Clearing Procedure

With the Short Pin removed, the occupant classification ECU and Center Airbag Sensor Assembly (airbag ECU) may detect the interruption in battery voltage (B+) and store a DTC. Clear DTC B1650 and B1794 after installing the Short Pin.

1. Connect TIS Techstream to the DLC3.
2. Turn the ignition switch to the "IG-ON" position.

Short Pin Installation During PDS

DTC Clearing Procedure (Continued)

3. Using TIS Techstream, check any other codes being output.

HINT

If any DTCs besides DTC B1650 and B1794 remain, repair the applicable system according to the Repair Manual.

4. Erase DTCs (B1650 and B1794) and Freeze Frame Data.