



TECHNICAL SERVICE BULLETIN

REF.: PRODUCT GENERAL
INFORMATION

NO.: PG92-002

DATE: JANUARY 24, 1992

MODEL: 1993 MR2

REMOVAL OF FRONT COIL SPRING SPACERS DURING PDS

Page 1 of 2

Temporary spring spacers are installed over the front suspension piston rods on 1993 MR2's to lift the vehicle body and prevent damage to the front spoiler during transportation loading and unloading.

Follow the procedures listed below to remove the spring spacers during Pre-Delivery Service (PDS).

Note: A caution label referring to removal of the spring spacers during PDS is also affixed to the inside front windshield.

POSITION OF SPRING SPACERS WHEN INSTALLED:

A spring spacer is installed over each front suspension piston rod as shown below:

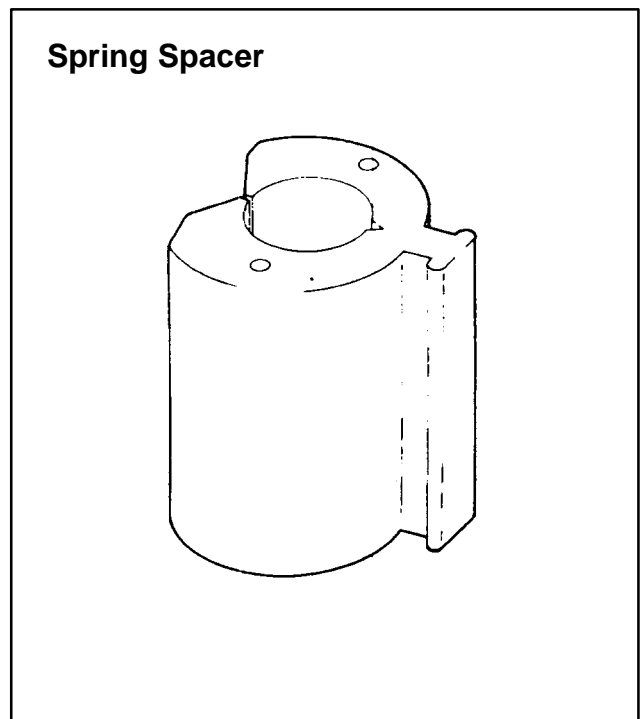
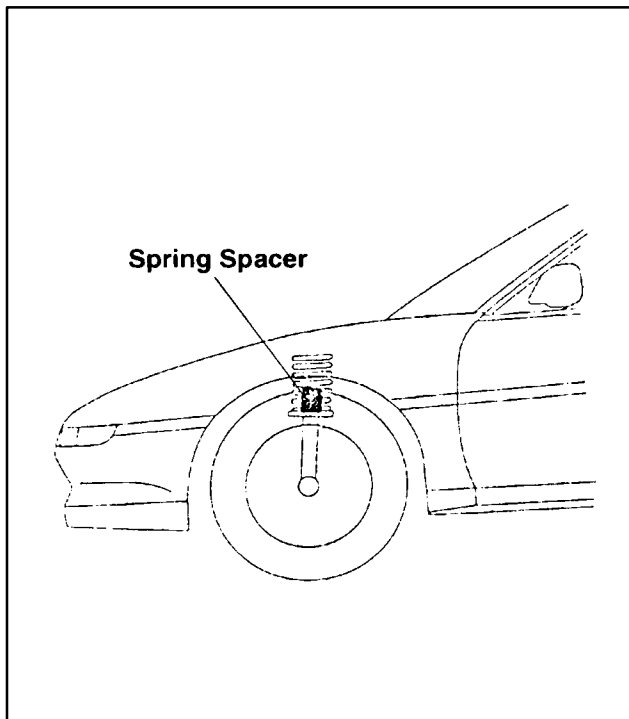

TOYOTA MOTOR SALES U.S.A., INC.

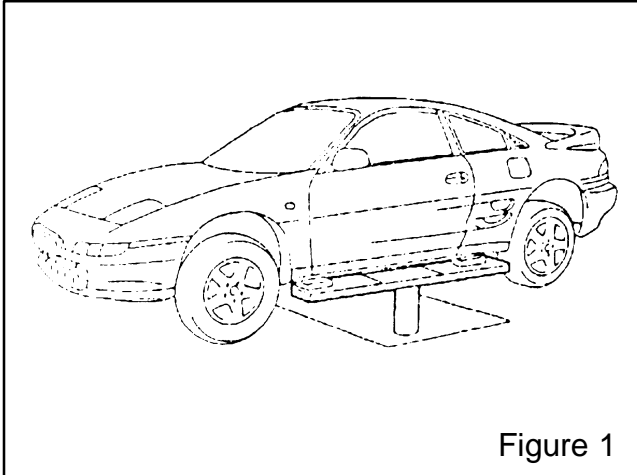

1. During the Underbody Checks portion of the Pre-Delivery Service, raise the vehicle on a hoist to extend the front suspension as shown in Figure 1.

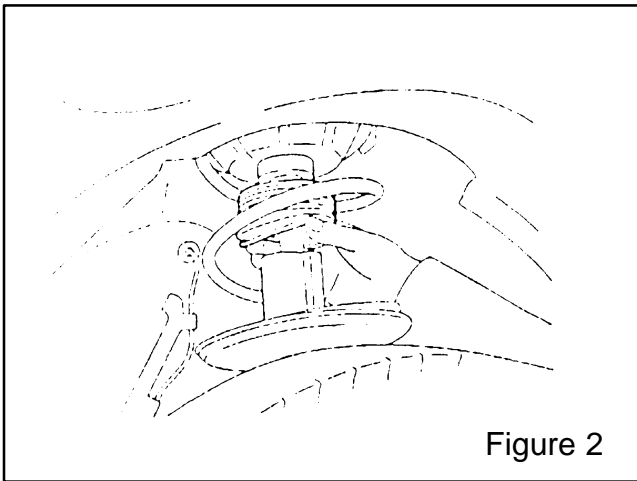

2. Push the dust cover upward to gain access to the spring spacer (see Figure 2).

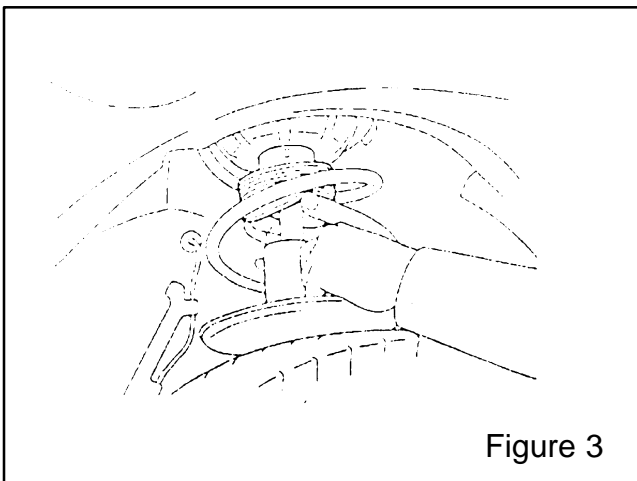

3. Pull out and remove the spring spacer as shown in Figure 3.
4. Reposition the dust cover.