



**Technical Service
BULLETIN**

June 24, 2003

Title:

**REAR SEAT CENTER ARMREST CUP
HOLDER RATTLE**

Models:

'03 4Runner



REVISION
 NV006-03
 H/V

TSB REVISION NOTICE:

September 30, 2003: VIN information has been added.

The previous TSB should be discarded.

Introduction Some customers may experience abnormal noise from the rear seat armrest cup holder while driving. The following procedure was developed to reduce noise from this area.

- Applicable Vehicles**
- **2003** model year **4Runner** vehicles produced **BEFORE** the Production Change Effective VINs shown below.

Production Change Information

MODEL	PLANT	PRODUCTION CHANGE EFFECTIVE VIN
4Runner	Tahara	JTEBT14R140028955
		JTEZT14R640014189
		JTEBU14R540022346
		JTEZU14R840019116
	Hino	JTEBT14R148009064
		JTEZT14R048003075
		JTEBU14R148012379
		JTEZU14R548010374

Parts Information

PREVIOUS PART NUMBER	CURRENT PART NUMBER	PART NAME	QTY
72830-350#0-#0	Same	Rear Seat Center Armrest Assembly	1

Warranty Information

OP CODE	DESCRIPTION	TIME	OFF	T1	T2
BD3006	Apply Felt Strips to Underside of Cup Holder	0.4	72830-350#0-#0	91	44
Combo A	Apply Felt Pieces to Topside of Cup Holder	0.2			

Applicable Warranty*:

This repair is covered under the Toyota Comprehensive Warranty. This warranty is in effect for 36 months or 36,000 miles, whichever occurs first, from the vehicle's in-service date.

* Warranty application is limited to correction of a problem based upon a customer's specific complaint.



**Required
Tools &
Material**

TOOLS & MATERIAL	PART NUMBER	QUANTITY
Noise Kit	08231-00801	1

**Repair
Procedure**

1. Open the rear seat center armrest cup holder.

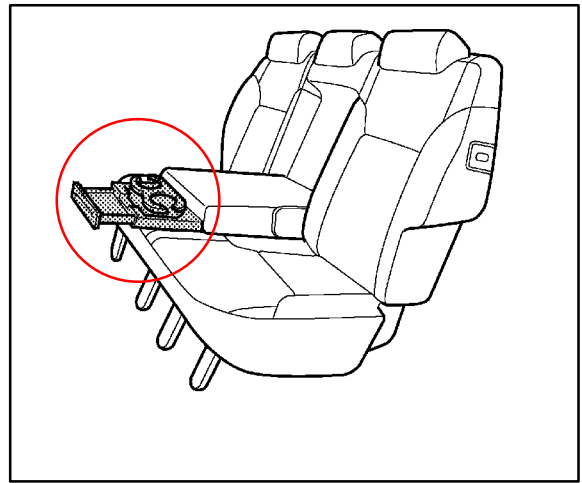

2. Fit two pieces of felt to the back side of the rear seat center armrest cup holder as shown.

**Length: 175.0 mm
Width: 10.0 mm
Thickness: 1.0 mm**

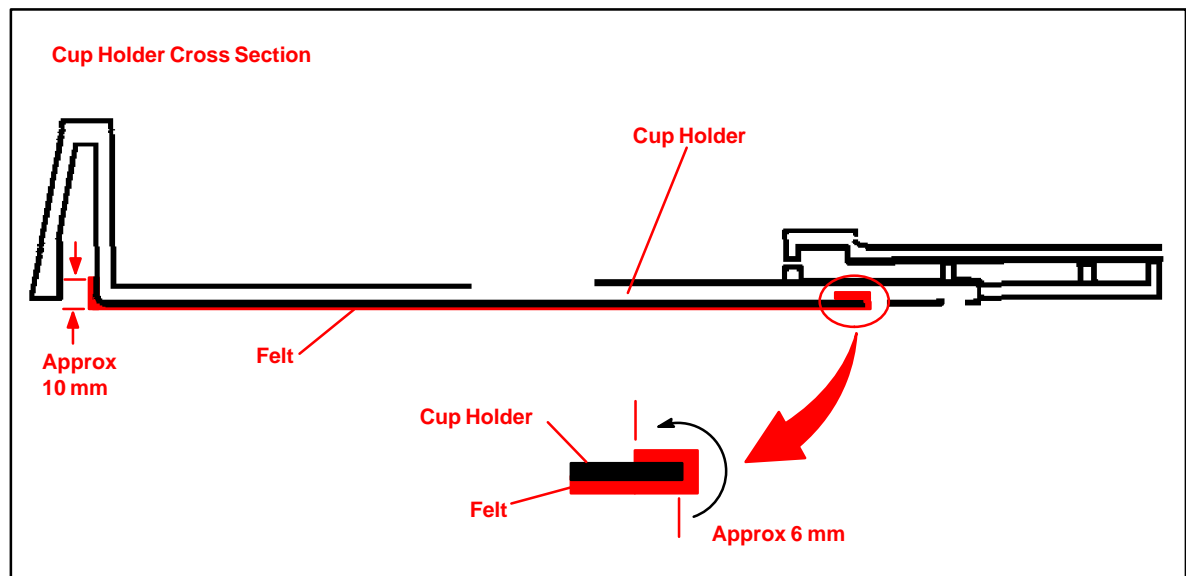
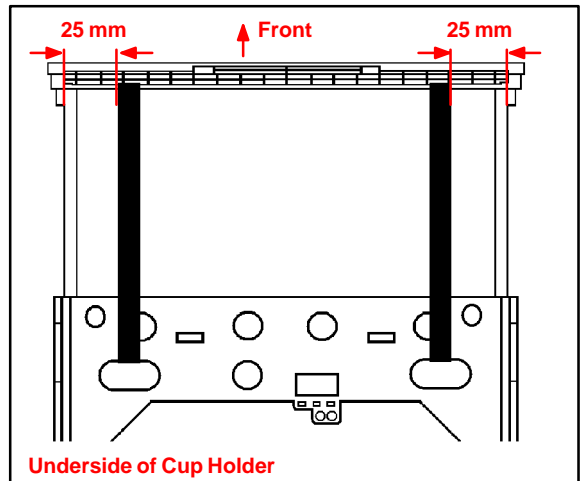

Repair Procedure
(Continued)

3. Cut two pieces of felt to the dimensions indicated below.

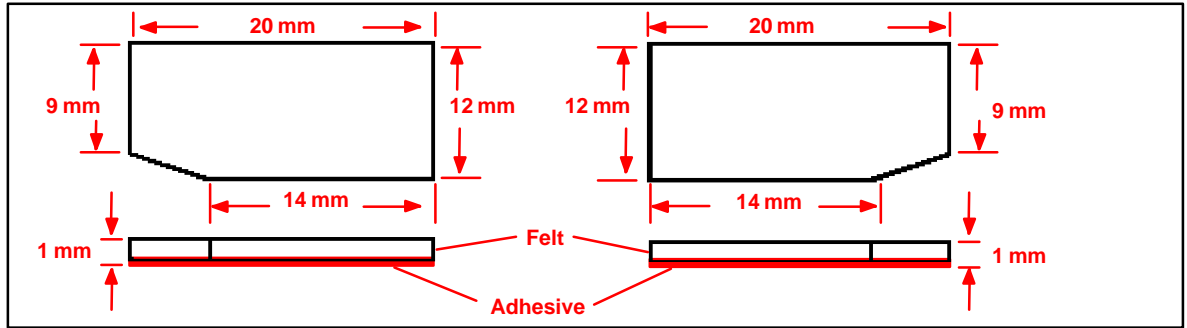

4. Place the two pieces of felt on top of the manufacturer applied felt in the locations indicated below.

