

TOYOTA

SERVICE BULLETIN

TOYOTA MOTOR SALES, U.S.A., INC.

VOLUME

9

REFERENCE BODY
NUMBER 011
DATE 01-29-88
MODEL ALL

Page 1 of 10

REAR SEAT 3-POINT SEAT BELT KITS

Rear seat 3-point seat belt retrofit kits for 1982-88 models are now available for installation at customer's expense. These kits may provide additional protection for rear seat passengers in certain accident circumstances.

KIT AVAILABILITY:

1982 - 1987 MODEL YEARS

Retrofit kits are available for all passenger and multi-purpose vehicles except Starlet and Land Cruiser.

1988 MODEL YEAR

Kits are available for Supra, Celica, Corolla, Tercel, FX, Van, Land Cruiser and 4-Runner.

Note: Rear 3-point seat belts are standard equipment on Cressida and Camry.

REAR SEAT 3-POINT SEAT BELT KITS (CONT'D)

CONTENTS OF THE KIT:

	<u>QTY</u>
[TYPE A] —Fig.1.	
SHOULDER BELT	: 1
LAP BELT, OUTER	: 1
LAP BELT, INNER	: 1

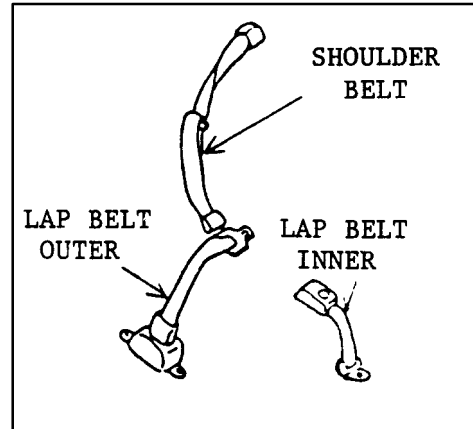

	<u>QTY</u>
[TYPE B] —Fig.2.	
SHOULDER BELT	: 1
LAP BELT, OUTER	: 1

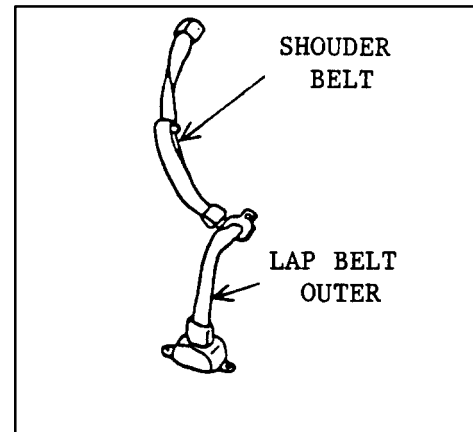

The original equipment inner lap belt is retained with the Type B Kit.

INSTALLATION PROCEDURE:

A detailed installation manual is included in each 3-point seat belt kit.

1. Remove the seat cushion, seat back and roof side inner garnishes for installation. (For vehicles with fold-down rear seat, seatback removal is not required.)
2. Remove the rear outer lap belts.
3. Make a 25 mm (1 in.) hole in each of the roof side inner garnishes from the back side where indicated in Fig. 3. Seat belt anchors have been originally installed on the vehicle in the form of weld nuts.
4. Reinstall the roof side inner garnishes.

REAR SEAT 3-POINT SEAT BELT KITS (CONT'D)

FX COROLLA

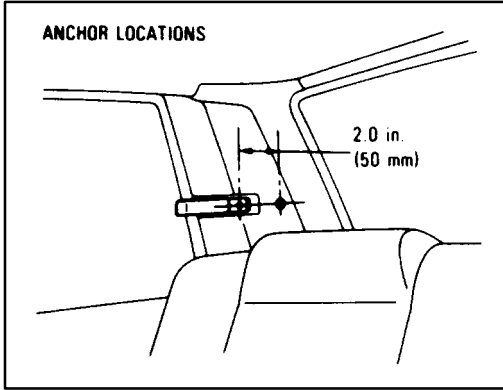

TERCEL 4WD WAGON

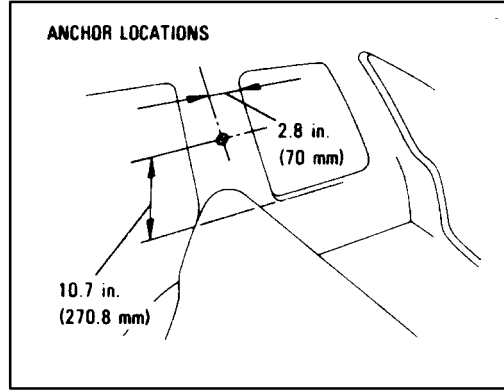

TERCEL

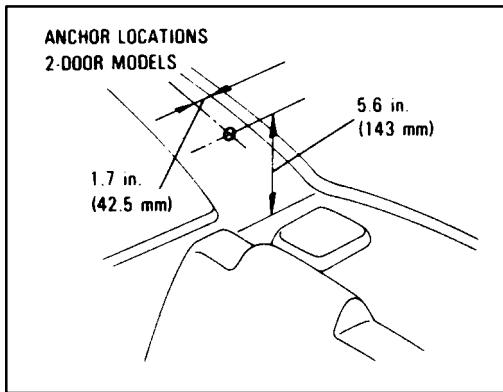

TERCEL

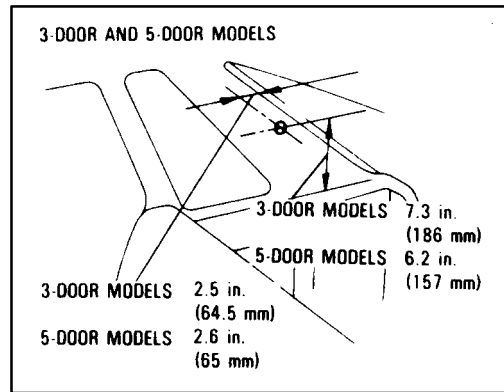

CELICA

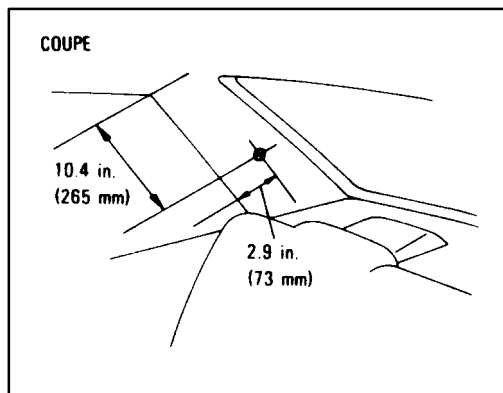

CELICA

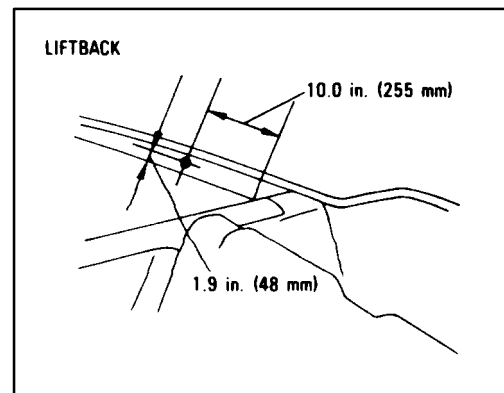
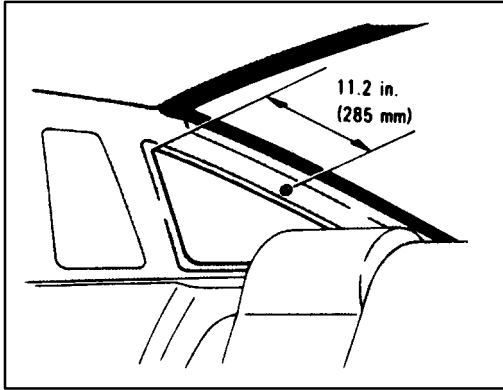

FIG. 3

REAR SEAT 3-POINT SEAT BELT KITS (CONT'D)

SUPRA



COROLLA

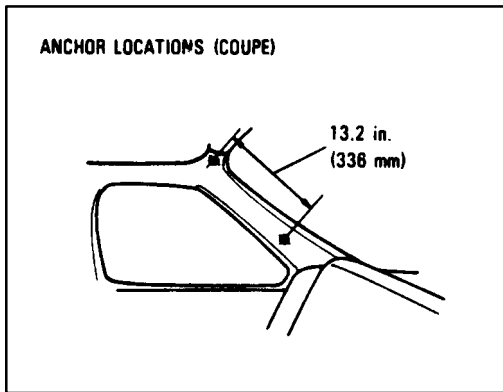

COROLLA

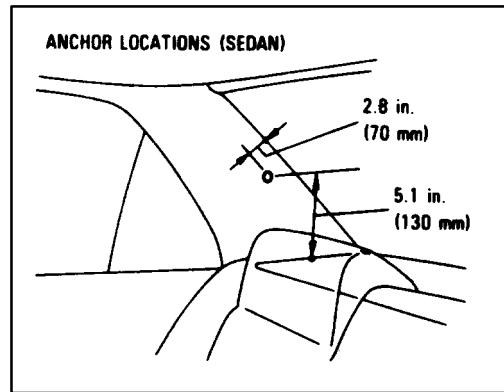
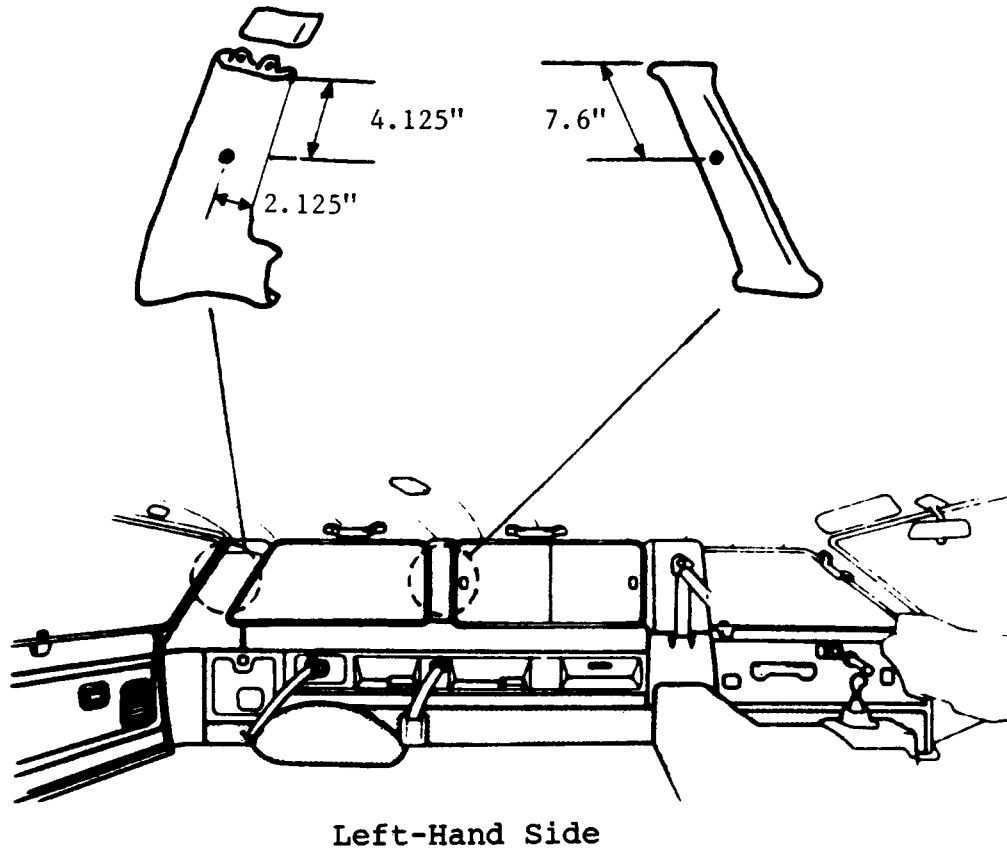

FIG. 3 (Cont'd)

REAR SEAT 3-POINT SEAT BELT KITS (CONT'D)

VAN



Left-Hand Side

LANDCRUISER (88 model only)

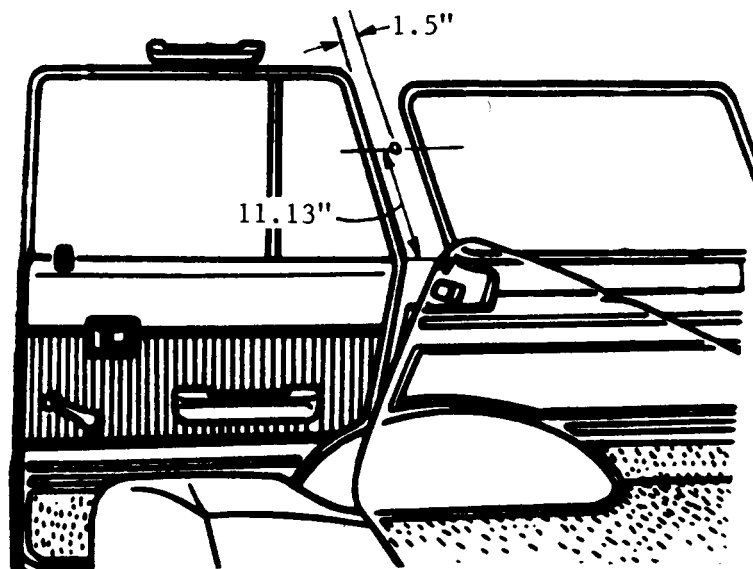

FIGURE 3 (cont.)

REAR 3-POINT SEAT BELT KITS (CONT'D)

5. Install the new rear outer (and inner) lap belts and shoulder belts supplied with the kit as shown in Fig. 4.

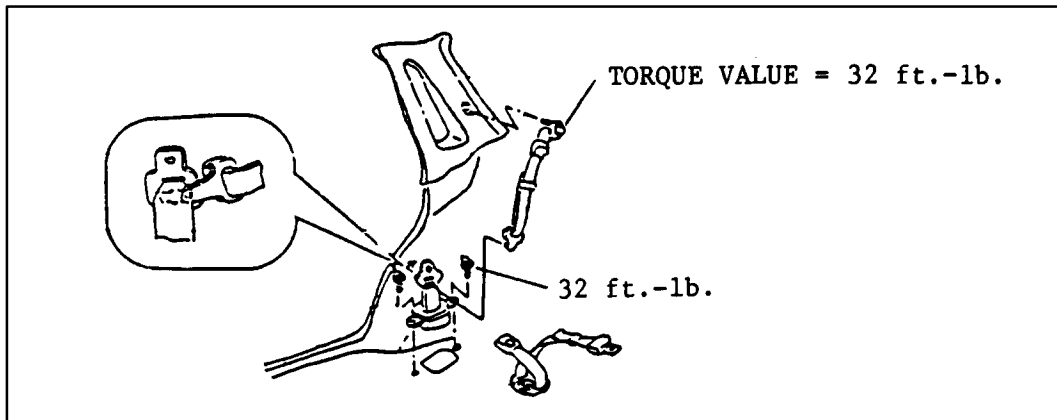

Fig. 4.

6. Install the seat cushion and seatback.
7. Roll the webbing back on the lap belt torque to expose the keyhole attachment slot for the shoulder belt. Insert the knob of the shoulder belt tab into the keyhole of the lap belt tab, and pull the knob to the arrow direction in Fig. 5. until a click is heard.

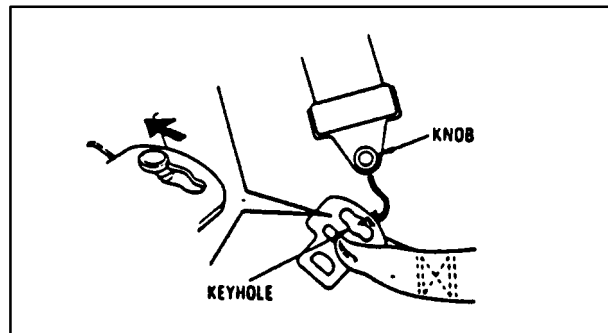

Fig. 5.

Make sure that the knob is connected securely and that the belt is not twisted. Be sure to route the shoulder belts above the retractable luggage cover, if the vehicle is so equipped.

INSTRUCTIONS FOR USING REAR 3-POINT SEAT BELTS

For detailed information on the lap belts, see the Owner's Manual.

1. Before fastening the lap belt, make sure that the belt is routed properly without twist and that the shoulder belt attaching knob is securely connected in the keyhole slot.

REAR 3-POINT SEAT BELT KITS (CONT'D)

2. Fasten the lap belt and adjust the lap belt position. If the shoulder belt is not long for you, hold the tab at a right angle to the belt and pull on the tab as shown in Fig. 6.

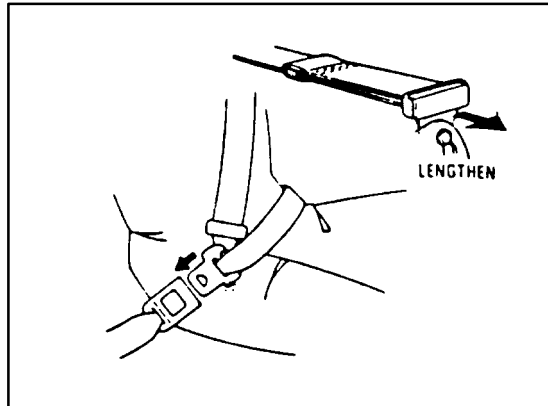

Fig. 6.

3. To shorten the shoulder belt, pull the free end of the belt. The shoulder belt slack should be no more than the thickness of your fingers between your chest and the belt, as shown in Fig. 7. Too much slack will render the belt ineffective in an accident. For your safety, do not place the shoulder belt under your arm and be careful so that the shoulder belt does not slide down from your shoulder.

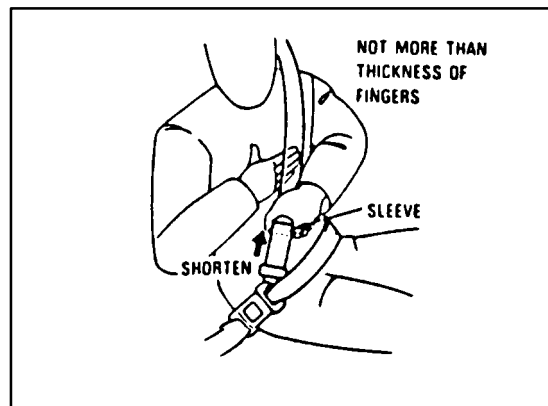

Fig. 7.

4. To release the belt, press the buckle release button.

When not in use, be careful not to let the belt become caught between the door and the vehicle body. If the vehicle has a fold-down rear seatback, do not let the belt become caught between the fold-down rear seatback and the seatback lock.

REAR 3-POINT SEAT BELT KITS (CONT'D)

PART NUMBER INFORMATION

MODEL	'82MY	'83MY	'84MY	'85MY	'86MY	'87MY	'88MY	
COROLLA	Z/R S/M	73003-12120 -01 73004-12130 -04 -06	•	•	•	•	•	•
	4/R S/M	73003-12120 -01 73004-12130 -04 -06	•	Fixing seat; 73003-12050 -02 73004-12050 -03 -04	Fold-down seat; 73003-12060 -03 73004-12060 -04 -06	•	•	(3P ALR DOPT) 73003-12090 -03 73004-12100 -04 -05
	H/T	73003-12130 -01 73004-12140 -04 -06	•	•	•	•	•	•
	H/B C/P	73003-12070 -01 73004-12080 -04 -06	•	73003-12020 -02 73004-12020 -03 -04	•	•	•	(3P ALR DOPT) 73003-12030 -03 73004-12030 -04 -05
	L/B	73003-12080 -01 73004-12090 -04 -06	•	73003-12010 -02 73004-12010 -03 -04	•	•	•	(3P ALR DOPT) •
	M/G	73003-13010 -01 73004-13020 -04 -06	•	•	•	•	•	•
	3/R	73003-16070 -01 73004-16070 -04 -06	•	•	•	•	•	•
	2/R S/M	73003-16070 -01 73004-16070 -04 -06	•	•	•	•	73003-02010 -L6 73004-02010 -R1	(3P ALR DOPT) •
	3/R	73003-16070 -01 73004-16070 -04 -06	73003-16060 -02 73004-16060 -03 -06	•	•	•	73003-16020 -01 73004-16020 -04 -05	(3P ALR DOPT) •
	4/R S/M	73003-16080 -01 73004-16080 -04 -06	•	•	•	•	73003-16050 -01 73004-16050 -04 -05	(3P ALR DOPT) •
TERCEL	S/M	73003-16060 -02 73004-16060 -03 -06	•	•	•	•	•	(3P ALR DOPT) •
	S/M	73003-16060 -02 73004-16060 -03 -06	•	•	•	•	73003-16010 -01 73004-16010 -04 -05	(3P ALR DOPT) •
	FF	73003-16030 -03 73004-16030 -06	•	73003-16030 -03 73004-16030 -06	•	•	•	(3P ALR DOPT) •
	M/G 4/R	73003-16040 -03 73004-16040 -06	•	•	•	•	73003-16010 -01 73004-16010 -04 -05	(3P ALR DOPT) •

REAR 3-POINT SEAT BELT KITS (CONT'D)**NOTE:**

- (1) The color of shoulder belt webbings is black except the parts used on '87 and '88 models, which can be ordered in the same color as the lap belt webbings.
- (2) The part numbers for '88 vehicles have been printed into microfiche by the following schedule:
 - (1) Celica and Land Cruiser : December, 1987
 - (2) Other models : September, 1987
- (3) Color code numbers of seat belt webbings are as follows:
01 - Black. 02, 12 - Red. 03, 13, 23 - Gray. 04 - Blue. 05, 15 - Beige.
06 - Brown. L6 - Dark Blue. R1 - Charcoal
- (4) If two numbers are specified in the table above, the upper number is for the right side seat belt and the lower number is for the left side seat belt.
- (5) When only one number is specified in the table above, this number is for both sides. Therefore, if you install the seat belts on this model, please place an order for 2 sets of kits.