

# TOYOTA

## SERVICE BULLETIN

TOYOTA MOTOR SALES, U.S.A., INC.

VOLUME





**10**

REFERENCE TRANSMISSION & CLUTCH  
 NUMBER 034  
 DATE 08-24-90  
 MODEL AE9#, EL3#, AW1#, ST6#, SV2#

### OIL STRAINER & ACCUMULATOR TUBES A13#, A14#, A24# DESIGN CHANGE

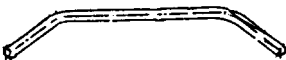

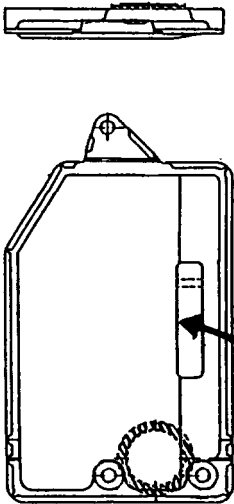
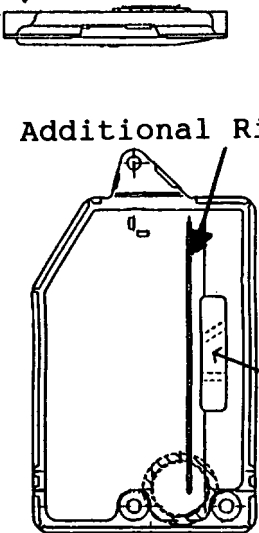

The oil strainer mesh and shape of the strainer have been changed. The brake and clutch accumulator tubes have been changed to accommodate the modified oil strainer (refer to illustrations for modifications).

1. A131L, A132L A/TM

PART NAME	PREVIOUS	NEW
Tube, Rear Clutch Accumulator		
Tube, Brake Accumulator		
Strainer Assy, Oil	 <p data-bbox="850 1688 927 1745">#120 Mesh</p>	<p data-bbox="1032 1247 1300 1339">Modified Shape (Only P/N 35330-20012)</p>  <p data-bbox="1036 1472 1308 1499">Additional Rib</p> <p data-bbox="1344 1692 1425 1749">#200 Mesh</p>

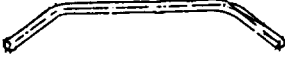

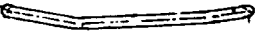

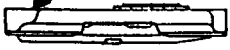
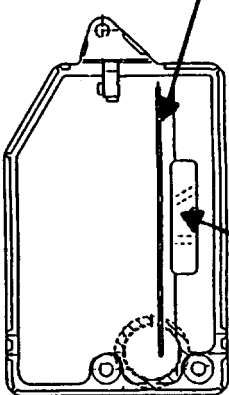
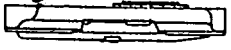
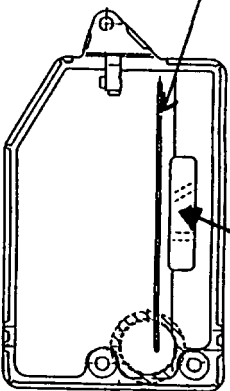
## OIL STRAINER & ACCUMULATOR TUBES DESIGN CHANGE (CONT'D)

2. A140L A/TM

PART NAME	PREVIOUS	NEW
Tube, Rear Clutch Accumulator		
Tube, Brake Accumulator		
Strainer Assy. Oil	<p style="text-align: center;">Modified Shape</p> <p style="text-align: center;"></p> <p style="text-align: center;">Additional Rib</p> <p style="text-align: center;"></p> <p style="text-align: right;">#120 Mesh</p>	<p style="text-align: center;">Modified Shape</p> <p style="text-align: center;"></p> <p style="text-align: center;">Additional Rib</p> <p style="text-align: center;"></p> <p style="text-align: right;">#200 Mesh</p>

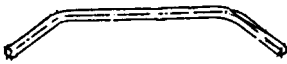
## OIL STRAINER & ACCUMULATOR TUBES DESIGN CHANGE (CONT'D)

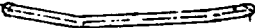
### 3. A140E A/TM

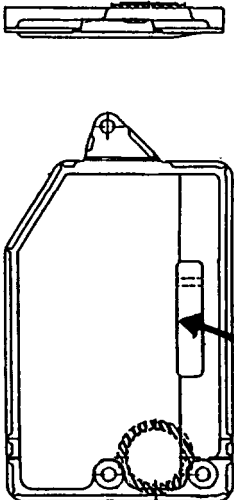
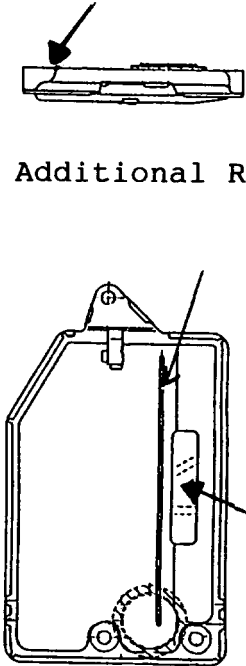
PART NAME	PREVIOUS	NEW
Tube, Rear Clutch Accumulator		
Tube, Brake Accumulator		
Strainer Assy. Oil	 <p style="text-align: right;">#120 Mesh</p>	<p>Modified Shape</p>  <p>Additional Rib</p> <p style="text-align: right;">#200 Mesh</p>

**OIL STRAINER & ACCUMULATOR TUBES DESIGN CHANGE (CONT'D)**

4. A240E A/TM

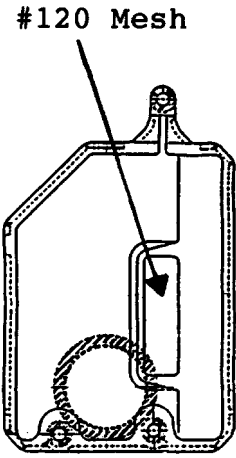
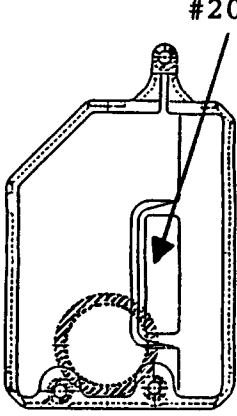
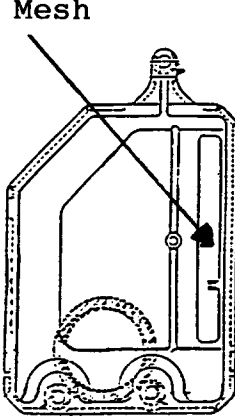
PART NAME	PREVIOUS	NEW	
Strainer Assy. Oil	 <p>#120 Mesh</p>	 <p>#200 Mesh</p> <p>35330-12011</p>	 <p>35330-12020</p>

**PRODUCTION EFFECTIVE:**

<u>STARTING VIN:</u>	<u>P/D</u>	<u>A/TM SERIAL No.</u>	<u>A/TM TYPE</u>
JT2AE9##K0138129 K3240593 K7051861 K8004057 K9016300	3/89	9BY05938 JB62000	A131L
JT2AE9##J0063050 J3092530 J7024109 J9006300 J8002250	3/88	8BZ00981	A240L
JT2EL3##K0393572	3/89	JB62000	A132L
JT2AW1##J0136329	3/88	8BZ00981	A240E
JT2ST6##K9050500	10/88 10/88	80900198 8J00351	A140L A140E
JT2SV2##K0255441	10/88	80900198	A140L
JT2SV2##K3332821	10/88	8J00351	A140E

## OIL STRAINER & ACCUMULATOR TUBES DESIGN CHANGE (CONT'D)

### PART NUMBER INFORMATION:

#### A131L A/TM

<u>PREV. PART No.</u>	<u>NEW PART No.</u>	<u>PART NAME</u>
35845-12020	*35845-12021	TUBE, Rr CLUTCH ACCUMULATOR
35846-12030	*35846-12031	TUBE, BRAKE ACCUMULATOR
35330-20010	*35330-20011**	STRAINER ASSY. OIL
	*35330-20012**	" " "

**\*PARTS ARE INTERCHANGEABLE AS A SET ONLY**

**\*\*THESE TWO PARTS ARE INTERCHANGEABLE**

#### A132L

<u>PREV. PART No.</u>	<u>NEW PART No.</u>	<u>PART NAME</u>
35845-32011	*35845-32012	TUBE, Rr CLUTCH ACCUMULATOR
35846-32021	*35846-32022	TUBE, BRAKE ACCUMULATOR
35330-20010	*35330-20011**	STRAINER ASSY. OIL
	*35330-20012**	" " "

**\*PARTS ARE INTERCHANGEABLE AS A SET ONLY**

**\*\*THESE TWO PARTS ARE INTERCHANGEABLE**

#### A140L A/TM

<u>PREV. PART No.</u>	<u>NEW PART No.</u>	<u>PART NAME</u>
35845-32021	*35845-32012	TUBE, Rr CLUTCH ACCUMULATOR
35846-32021	*35846-32022	TUBE, BRAKE ACCUMULATOR
35330-32020	*35330-32022	STRAINER ASSY. OIL

**\*PARTS ARE INTERCHANGEABLE AS A SET ONLY**

#### A140E

<u>PREV. PART No.</u>	<u>NEW PART No.</u>	<u>PART NAME</u>
35845-32011	*35845-32012	TUBE, Rr CLUTCH ACCUMULATOR
35846-32011	*35846-32012	TUBE, BRAKE ACCUMULATOR
35330-32020	*35330-32022	STRAINER ASSY. OIL

**\*PARTS ARE INTERCHANGEABLE AS A SET ONLY**

**OIL STRAINER & ACCUMULATOR TUBES DESIGN CHANGE (CONT'D)**

**A240L/A240E**

<b><u>PREV. PART No.</u></b>	<b><u>NEW PART No.</u></b>	<b><u>PART NAME</u></b>
35330-12020	35330-12011**	STRAINER ASSY. OIL
	35330-12020**	" " "

**\*\*THESE TWO PARTS ARE INTERCHANGEABLE**