



**Technical Service
BULLETIN**

July 12, 2006

Title:
**MANUAL WINDOWS JUMP
WHEN OPENING**

Models:
'03 – '05 Matrix

BODY
B0013-06

Introduction Some customers may notice that the front window glass will jump down slightly from the fully closed position when first opening the window. The window run has been improved to correct this condition.

**Applicable
Vehicles**

- **2003 – 2005** model year **Matrix** vehicles with **manual windows**.

Part numbers vary based on the vehicle production (refer to the VIN table below and the Parts Information table in this TSB).

MODEL	PLANT	VIN RANGE	REFERENCE NUMBER*
Matrix	TMMC	Before 2T1KR32E93C009928	3, 4
		2T1KR32E93C009928 to 2T1KR32E63C010597	3, 2
		After 2T1KR32E63C010597	1, 2

* This number corresponds with the Reference Number column of the Parts Information table in this TSB.

**Parts
Information**

REFERENCE NUMBER*	PREVIOUS PART NUMBER	CURRENT PART NUMBER	PART NAME	QTY
1	68141-01060	68141-01061	Run, FR Door Glass, RH	1
2	68151-01050	68151-01051	Run, FR Door Glass, LH	1
3	68141-01040	68141-01070	Run, FR Door Glass, RH	1
4	68151-01030	68151-01060	Run, FR Door Glass, LH	1

* This number corresponds with the Reference Number column of the Applicable Vehicles table in this TSB.

**Warranty
Information**

OP CODE	DESCRIPTION	TIME	OPF	T1	T2
BD5030	R & R Front Door Glass Run (One Side)	0.5	681#1-02##0	62	13
Combo A	Opposite Side	0.4			

Applicable Warranty*:

This repair is covered under the Toyota Comprehensive Warranty. This warranty is in effect for 36 months or 36,000 miles, whichever occurs first, from the vehicle's in-service date.

* Warranty application is limited to correction of a problem based upon a customer's specific complaint.



Required Tools & Material

TOOLS & MATERIAL	QUANTITY
Kent™ Acrysol	As Needed

NOTE:
Parts can be obtained from the local Kent™ representative or from Kent™ nationally at 1-800-654-6333.

Required SSTs

ITEM NO.	SPECIAL SERVICE TOOLS (SSTs)	PART NUMBER	QTY	DRW**
1	Plastic Pry Tool Set*	00002-06000-01	1	20
COMPONENT(S) OF KIT/SET	<p>NOTE:</p> <ul style="list-style-type: none"> All components from this kit/set are required. Plastic Panel Clip Removal Tool (P/N 00002-06001-01) Plastic Emblem Removal Tool (P/N 00002-06002-01) 			

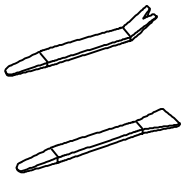

* Essential SSTs.
 ** Refers to drawer number in SST Storage System.

NOTE:
Additional SSTs may be ordered by calling SPX/OTC at 1-800-933-8335.

Repair Procedure

NOTE:
Complete the procedure for both the LH and RH sides.

1. Place the window in the down position.
2. Remove the front door window regulator handle assembly.
 - A. Insert a clip remover between the plate and trim.
 - B. Maintain the position in step A and turn the handle as shown in the illustration to remove the handle.

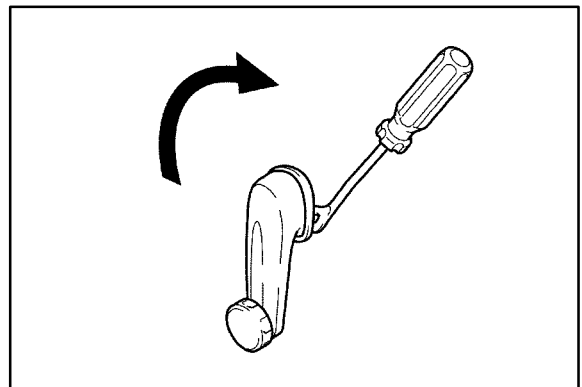

Repair Procedure
(Continued)

3. Remove the front door pull handle.
 - A. Remove the screw.
 - B. Using the plastic pry tool or a screwdriver, remove the door pull handle.

HINT:
Tape the screwdriver tip before use.

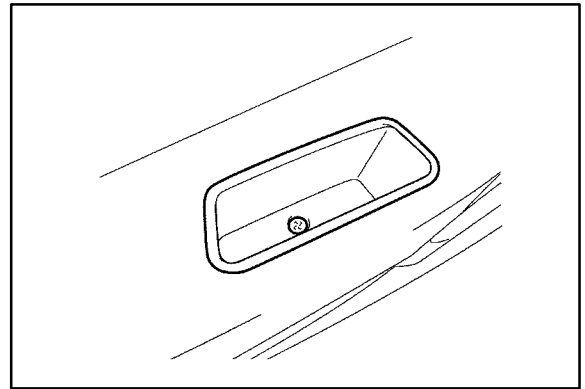

4. Remove the front armrest base panel upper.
 - **With Power Door Lock:** Remove the armrest base panel from the trim board by using the plastic pry tool or the taped screwdriver.
 - a. Disconnect the door lock switch connector.
 - b. Remove the door lock switch from the base panel.
 - **Without Power Door Lock:** Remove the armrest base panel from the trim board by using the plastic pry tool or the taped screwdriver.

5. Remove the front door lower frame bracket garnish by using the taped screwdriver to disengage the clip and claw.

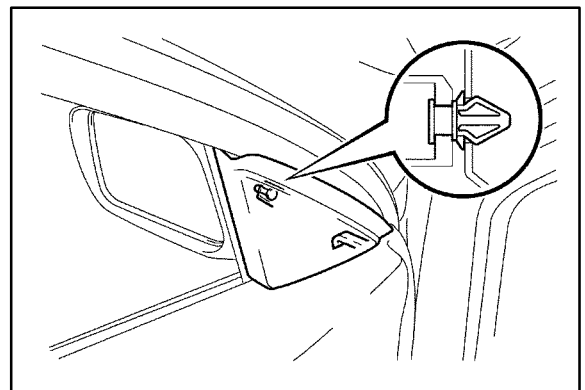

6. Remove the front door trim board sub-assembly.
 - A. Remove the screw.
 - B. Using the taped screwdriver, disengage the seven (7) clips and pull the trim board upward to remove it.

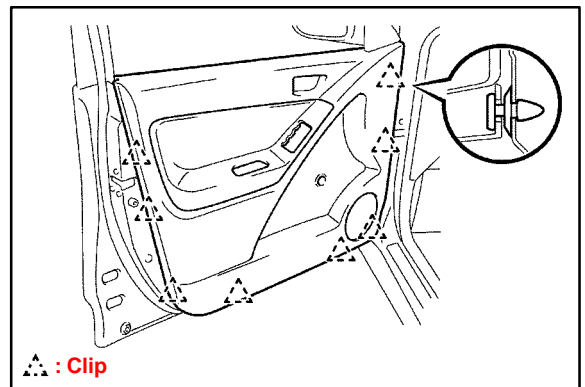

**Repair
Procedure**
(Continued)

7. Remove the window run.
Completely remove the double-sided tape remaining on the frame.
8. Thoroughly clean the door frame using a white body shop towel and Kent™ Acrysol.

NOTE:

Do NOT use red shop towels. These towels contain silicone.

9. Install the door glass window run.
 - A. Position the glass run at the No. 2 and No. 3 corners of the door frame and then attach the middle part of the run.
 - B. Insert the glass run into the window run channels.

NOTE:

- **Do NOT apply water or lubricant to the glass run when inserting it into the door.**
- **Make sure the glass run fits securely into the holes of the door frame.**

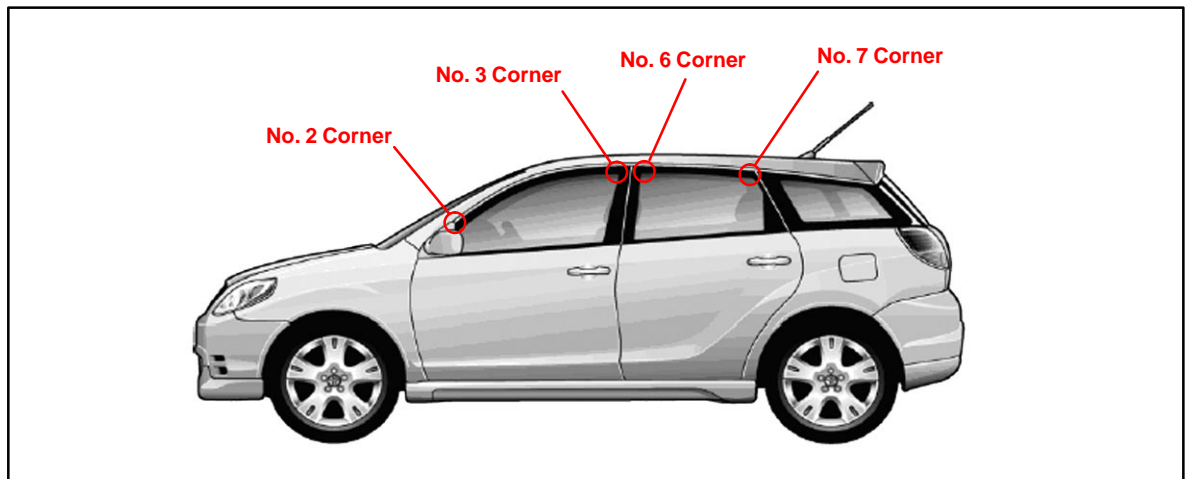

10. Using a plastic pry tool, press the glass run into the upper portion of the door frame to securely adhere the double-sided tape.
11. Fully close the window and leave closed for 24 hours.
12. Confirm that the windows do NOT jump when opening.