



**Technical Service
BULLETIN**

October 14, 2004

Title:

**MAIN BEARING JOURNAL DIAMETER
STAMPING LOCATION REVISION**

Models:

'04 – '05 Avalon, Camry & Highlander

ENGINE
EG044-04

Introduction The main bearing journal diameter stamp location has been changed on some 2004 and 2005 model year vehicles with 1MZ-FE or 3MZ-FE engines. The stamping on the front of the block has been discontinued. Review this TSB for the stamping location.

- Applicable Vehicles**
- **2004 – 2005** model year **Avalon, Camry and Highlander** vehicles meeting the following specifications:
 - **1MZ-FE** equipped vehicles with **engine serial numbers starting after 1728661**.
 - **3MZ-FE** equipped vehicles with **engine serial numbers starting after 0138096**.

Warranty Information

OP CODE	DESCRIPTION	TIME	OFF	T1	T2
N/A	Not Applicable to Warranty	–	–	–	–



Main Bearing Location

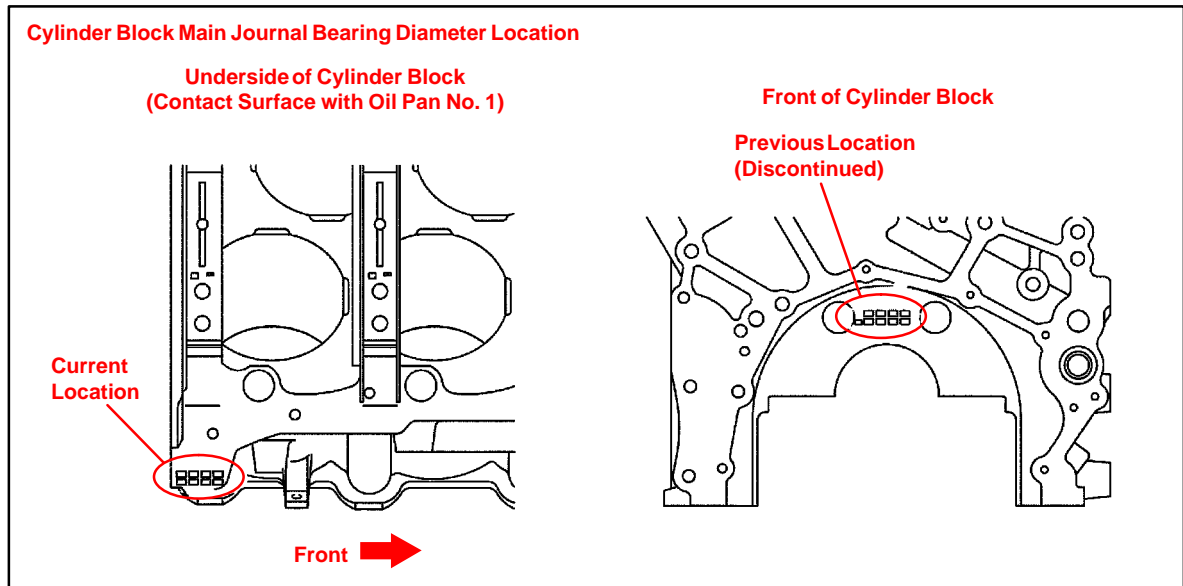

HINT:
 If replacing a bearing, replace it with one that has the same number. If the number of the bearing cannot be determined, select the correct bearing by adding together the numbers imprinted on the cylinder block and crankshaft, then refer to the table on the bottom of this page for the appropriate bearing number. The No. 1 and No. 4 journal bearings have 5 standard bearing sizes, marked 3, 4, 5, 6, and 7 accordingly. The No. 2 and No. 3 journal bearings have 5 standard bearing sizes, marked 1, 2, 3, 4, and 5 accordingly.

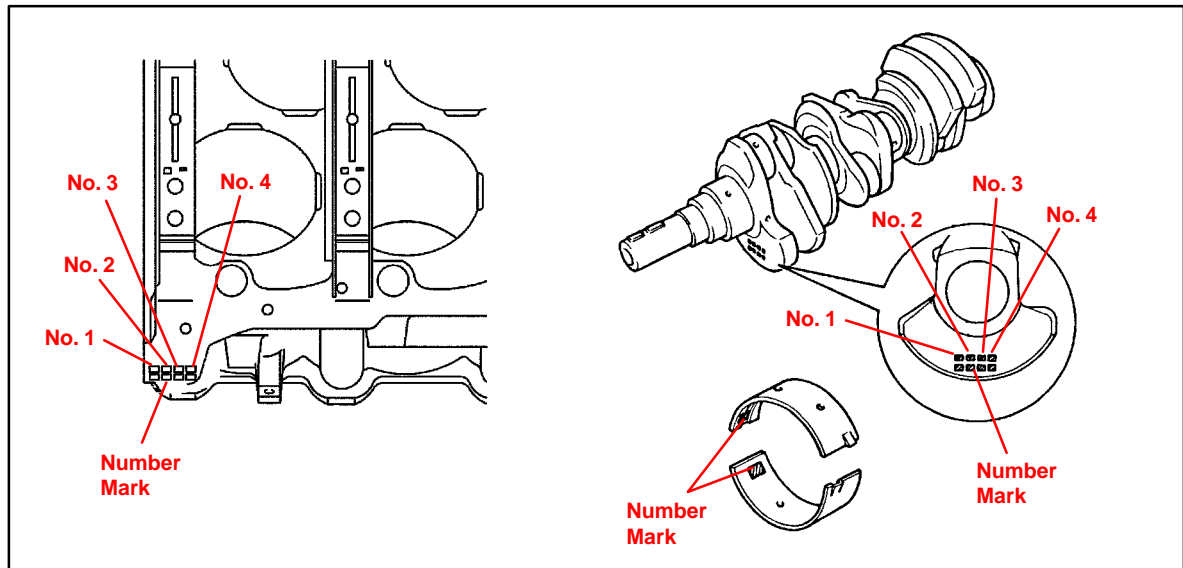

Cylinder Block + Crankshaft =	0 to 5	6 to 11	12 to 17	18 to 23	24 to 28
Replacement Bearing	3	4	5	6	7

EXAMPLE:
 Cylinder block imprinted number mark is "06."
 Crankshaft imprinted number mark is "08."
 $6 + 8 = 14$
 Select the bearing marked "5."