



**Technical Service
BULLETIN**

November 28, 2002

Title:
FRONT SEAT SQUEAK
Models:
'03 4Runner

T S B

**NV/H
NV010-02**

Introduction Some customers may experience a squeak/creak noise from the front seats. The following procedures have been developed to reduce this noise.

- Applicable Vehicles**
- **2003** model year **4Runner** vehicles.

Parts Information

PREVIOUS PART NUMBER	CURRENT PART NUMBER	PART NAME	QTY
08231-00801	Same	Noise Kit	1
90468-16019	Same	Hog Rings	5

Warranty Information

OP CODE	DESCRIPTION	TIME	OFP	T1	T2
NV1021	Loosen Seat Back Cover and Re-install	0.7	71073-3G280-## 71073-3G440-##	91	99
NV1022	Cut Felt to Size and Apply to Wire	0.1	71074-35620-## 71074-35640-##		

Applicable Warranty*:

This repair is covered under the Toyota Comprehensive Warranty. This warranty is in effect for 36 months or 36,000 miles, whichever occurs first, from the vehicle's in-service date.

* Warranty application is limited to correction of a problem based upon a customer's specific complaint.



**Repair
Procedure:
Leather Seat**

Leather Seat

1. Remove the 4 seat track covers and 4 seat track mounting bolts.
2. Remove the headrest assembly.
3. Tilt the seat forward.
4. Disconnect the two seat backboard cover rubber bands from the hooks.

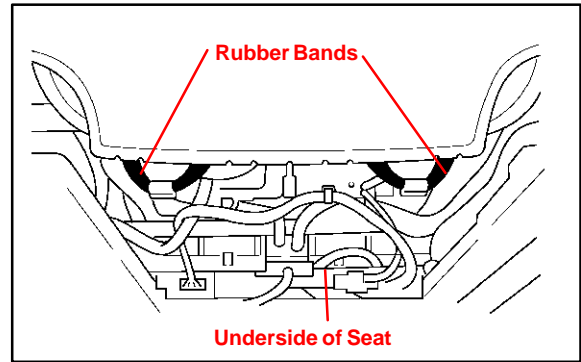

5. Lift up the seat backboard cover, and remove the two front seat backboard installation screws.
6. Temporarily reinstall the four seat track mounting bolts.

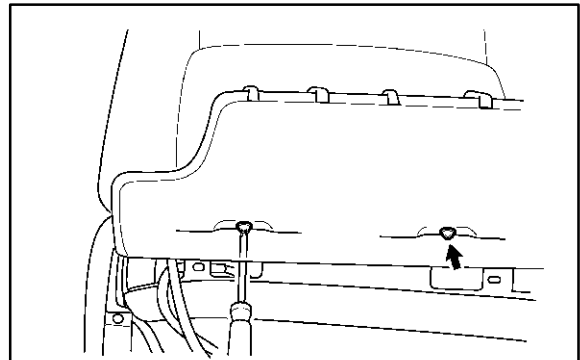

7. Remove the seat backboard.
 - A. While pressing the board to the vehicle front side (push in on the backboard), pull the backboard toward the seat center in order to disconnect the two claws (A) on each of the side surfaces of the board.
 - B. While pressing the board toward the vehicle front side, pull it downward and disconnect the two claws (B) at the top of the board.

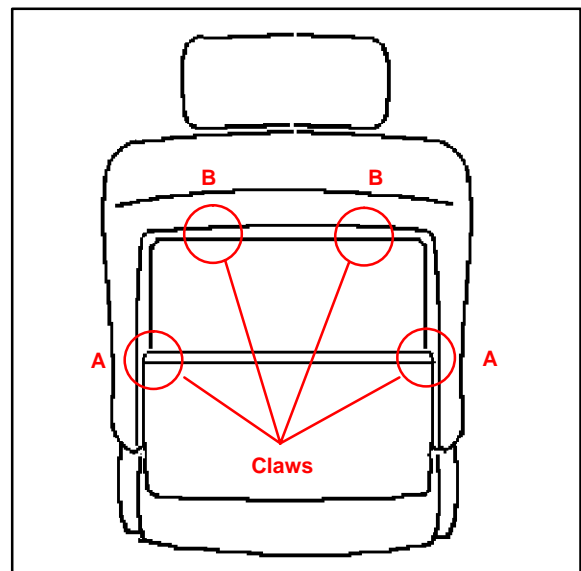

8. Disconnect the six plastic seat cover hooks from the seat frame wire and the two plastic seat cover hooks from the front seat backboard cover.

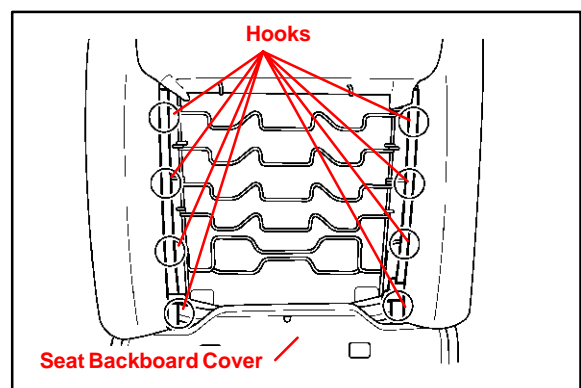

NOTE:

Early production vehicles may have only four plastic seat cover hooks connected to the seat frame wire.

Repair Procedure:
Leather Seat
(Continued)

9. Pull the front seat backboard cover up and remove it.
10. Remove the three hog rings that secure the seat back cover and the two hog rings that secure the bands to the seat frame.

NOTE:
Early production vehicles may have only three hog rings that secure the seat back cover and no bands.

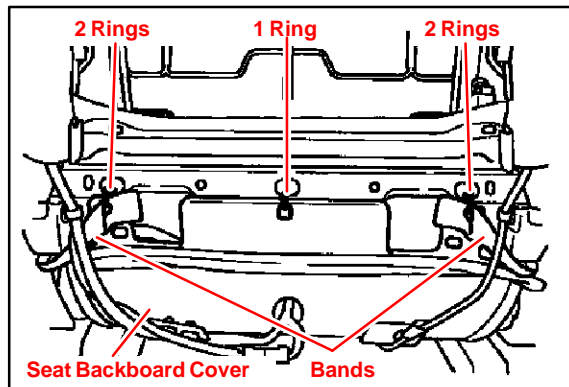

11. Push the seat back pad forward until the lower rear end of the pad is wedged in front of the connecting rod.

NOTE:
Be careful not to push on the pads with excessive force because they could be torn or the wire harness could be disconnected.

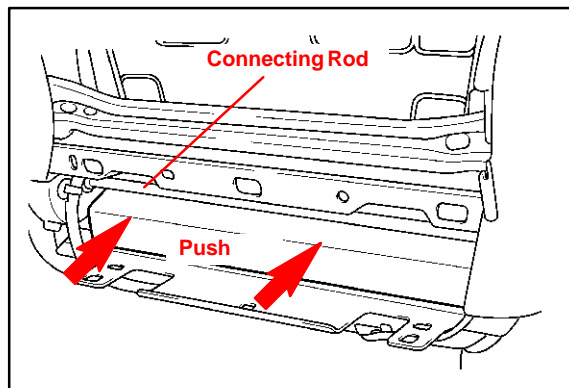

12. For seats equipped with side airbag: Remove the seat back cover bracket set nut (bracket found only on the outside seat back frame rail).

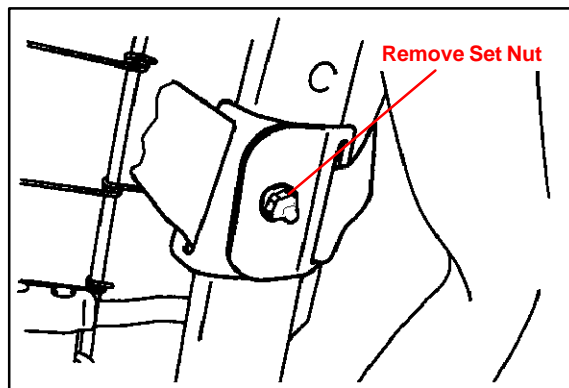

13. For seats equipped with side airbag: Remove the two seat back cover brackets from the frame.

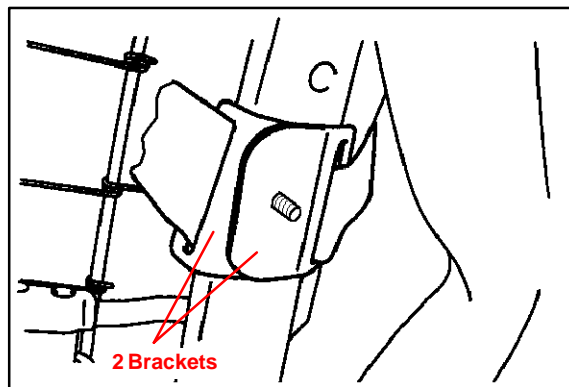

Repair Procedure:
Leather Seat
 (Continued)

14. While moving the seat back pad to gain access to the seat frame, attach a piece of felt to the wire.

Felt Size:

Length: 185 mm

Width: 40 mm

Thickness: 2 mm

NOTE:

- Be careful not to open the pad too much as the seat back pad could tear.
- Securely align the felt as shown in the illustration so that it cannot come off.
- Be sure to align the overlapping felt so it faces towards the rear of the vehicle as shown.

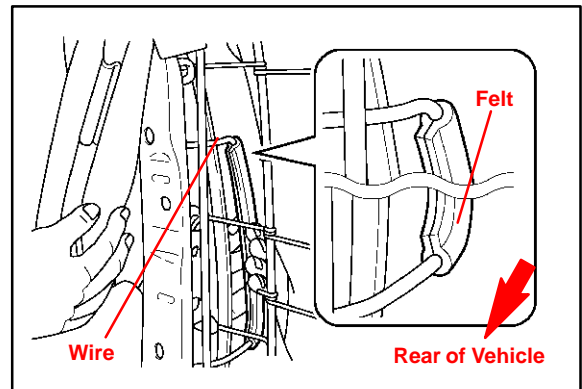

15. Repeat step 14 for the opposite side.
16. For seats equipped with side airbag: Install the inner bracket to the frame, and then install the outer bracket.

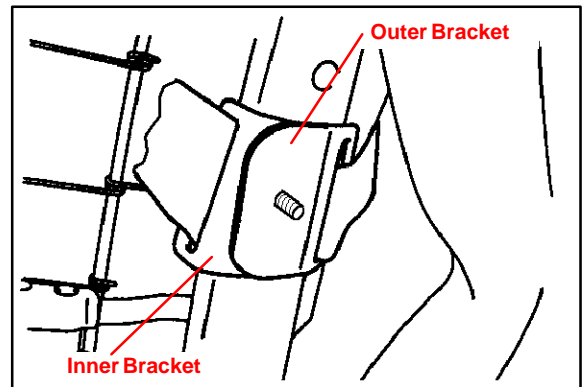

17. For seats equipped with side airbag: Install and tighten the set nut.

Torque: 5.5 N-m (56 kgf-cm, 48 in.-lbf)

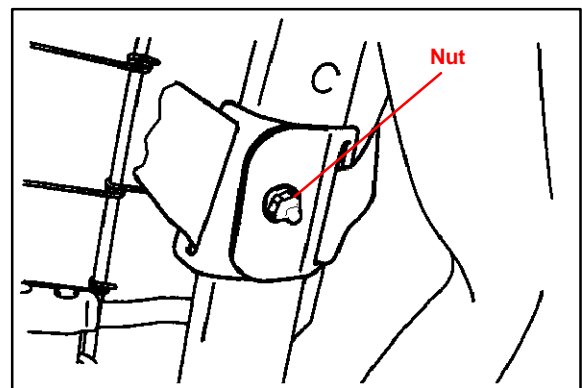

**Repair
Procedure:
Leather Seat
(Continued)**

18. Pull out the front seat back pad to the bottom of the connecting rod (original position).

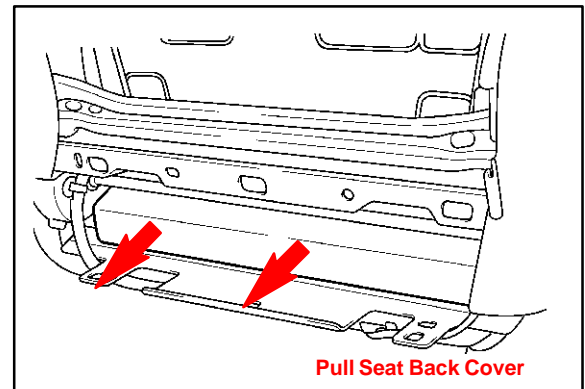

19. Place the resin plates of the seat back cover between the frame and inner cover.

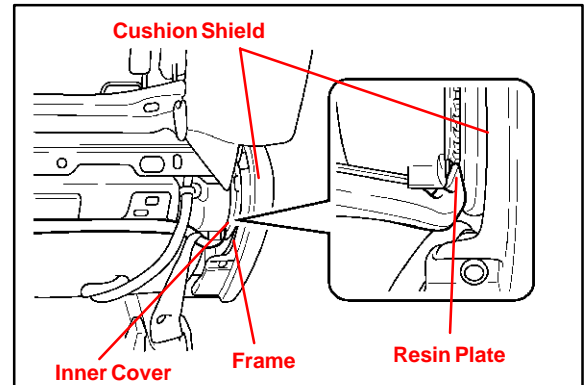

20. Pull the flap of the seat back cover up and affix it to the frame with hog rings using hog ring pliers.

NOTE:

- Be sure to use coated hog rings (90468-16019) to prevent any abnormal noise.
- Non-reusable part.

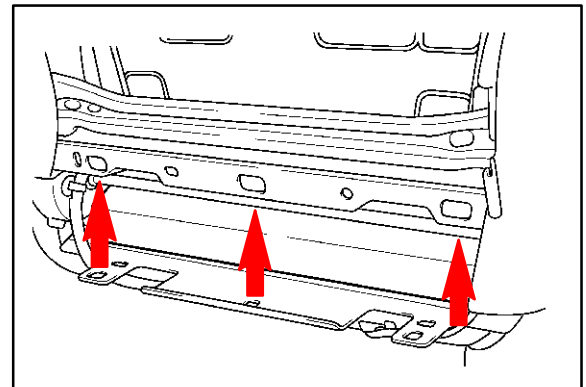

21. Pull out the bands at both ends of the seat back cover and affix them with hog rings using hog ring pliers.

NOTE:

Skip this step if the vehicle has no bands.

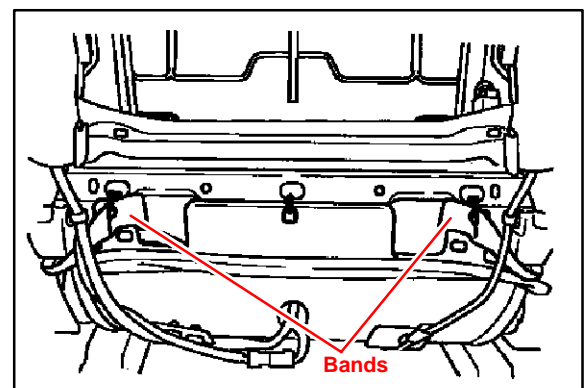

**Repair Procedure:
Leather Seat
(Continued)**

- 22. Position the seat back cover end between the cushion shield and the frame.

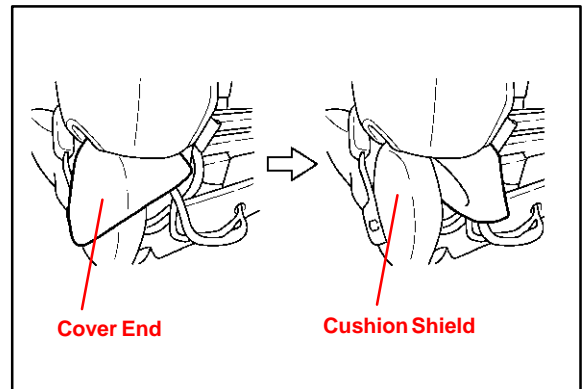

- 23. Install the seat backboard cover.
 - A. Slide the seat backboard cover hook onto the frame.
 - B. Position both ends between the seat back pad and frame.

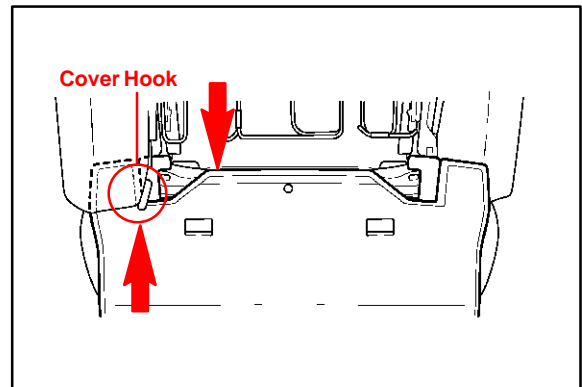

- 24. Connect the six hooks of the seat cover to the seat frame wire and the two hooks of the seat cover to the seat backboard cover.

NOTE:
Early production vehicles may have only four plastic seat cover hooks connected to the seat frame wire.

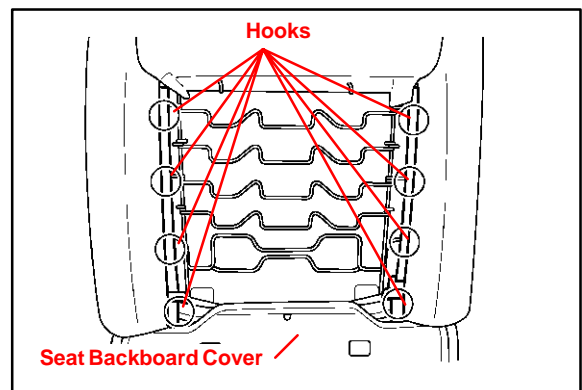

- 25. Re-install the seat backboard in reverse order of step 7 A and B.

NOTE:
There should be no wrinkles or gaps on the fitting surfaces. Be sure that the four claws are securely engaged.

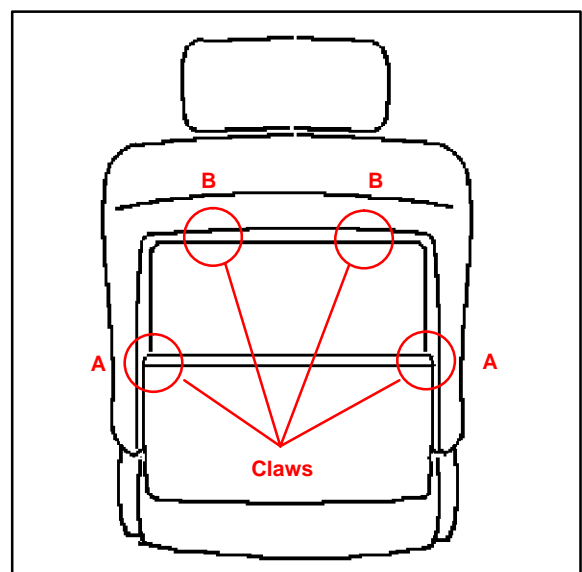

- 26. Remove the four seat track mounting bolts.
- 27. Turn up the front seat backboard cover, then install the two front seat backboard installation screws.
- 28. Lift up the seat back side of the seat.

**Repair
Procedure:
Leather Seat
(Continued)**

29. Connect the two seat backboard cover rubber bands to the hooks.
30. Insert your fingers between the board and seat surface to check whether the four claws are securely hooked.
31. Install the four seat track mounting bolts.

Torque: 37 N–m (375 kgf–cm, 27 ft–lbf)

32. Install the four seat track covers.
33. Install the headrest assembly.
34. Fully recline the seat back, lightly grasp the portions shown by the circles in the illustration and lightly pull in the direction of the arrow. Check that the seat back pad cannot be seen.

HINT:

If the resin plates shown in step 19 are out of position, the seat back pad can be seen during this check.

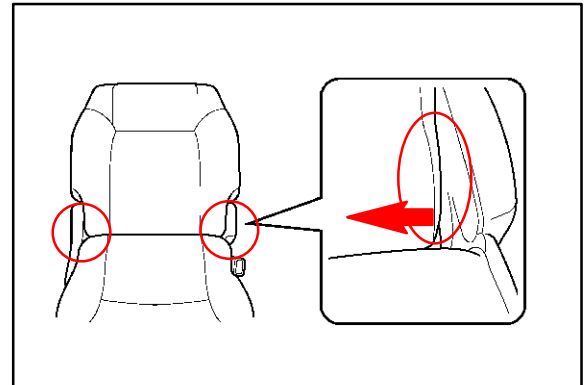

**Repair
Procedure:
Fabric Seat**

Fabric Seat

1. Remove the 4 seat track covers and 4 seat track mounting bolts.
2. Remove the headrest assembly.
3. Tilt the seat forward.
4. Disconnect the two seat backboard cover rubber bands from the hooks.
5. Temporarily reinstall the four seat track mounting bolts.
6. Lift up the seat back board cover, and remove the three hog rings that secure the seat back cover and the two hog rings that secure the seat back cover end to the seat frame. Unzip the seat fastener.

NOTE:

Early production vehicles may have two more hog rings that secure the end of the seat fastener to the seat frame. In this case, remove these two hog rings also.

7. Push the seat back pad forward until the lower rear end of the pad is wedged in front of the connecting rod.

NOTE:

Be careful not to push on the pads with excessive force because they could be torn or the wire harness could be disconnected.

8. For seats equipped with side airbag: Remove the seat back cover bracket set nut (bracket found only on the outside seat back frame rail).

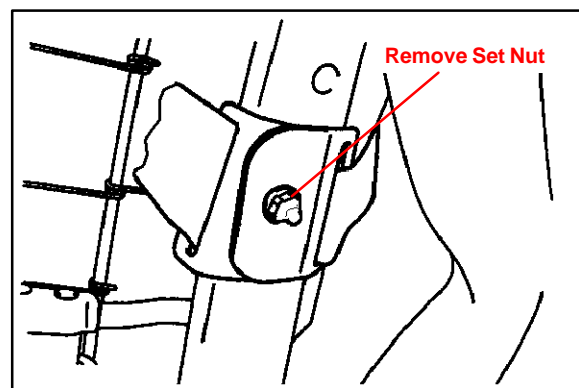
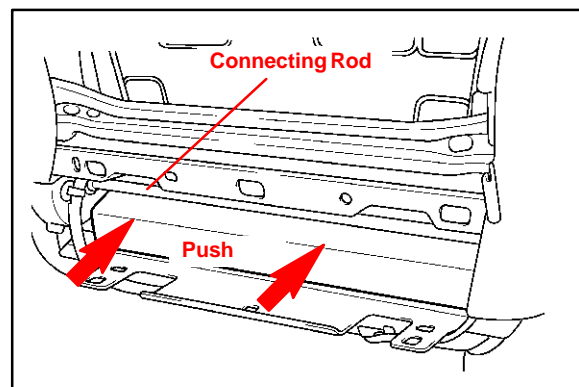
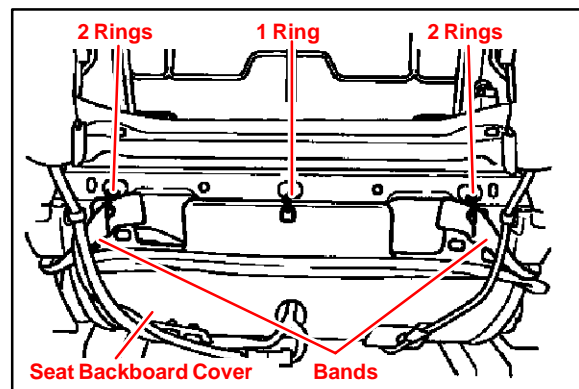
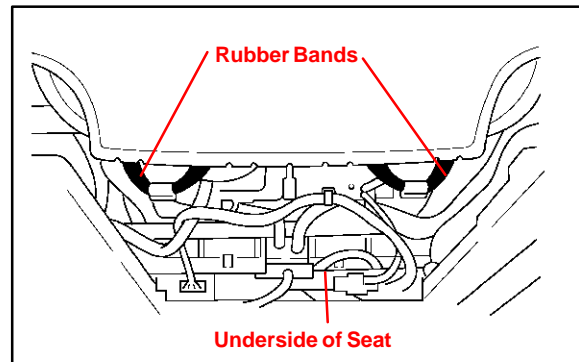

**Repair
Procedure:
Fabric Seat
(Continued)**

9. For seats equipped with side airbag:
Remove the two seat back cover
brackets from the frame.

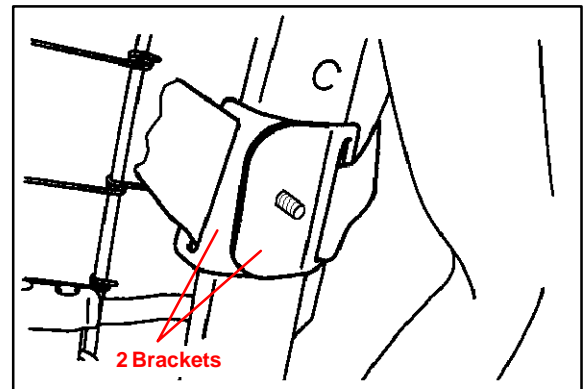

10. While moving the seat back pad to
gain access to the seat frame, attach
a piece of felt to the wire.

Felt Size:

Length: 185 mm
Width: 40 mm
Thickness: 2 mm

NOTE:

- Be careful not to open the pad too much as the seat back pad could tear.
- Securely align the felt as shown in the illustration so that it cannot come off.
- Be sure to align the overlapping felt so it faces towards the rear of the vehicle as shown.

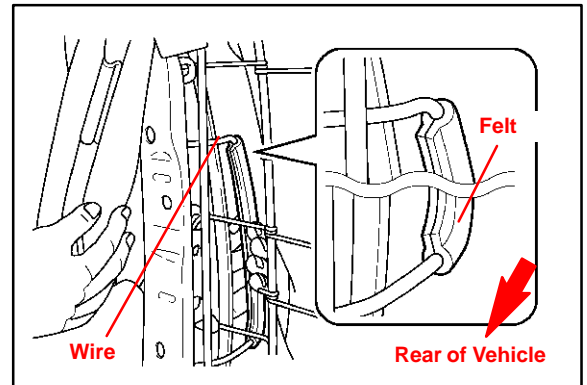

11. Repeat step 10 for the opposite side.
12. For seats equipped with side airbag:
Install the inner bracket to the frame,
and then install the outer bracket.

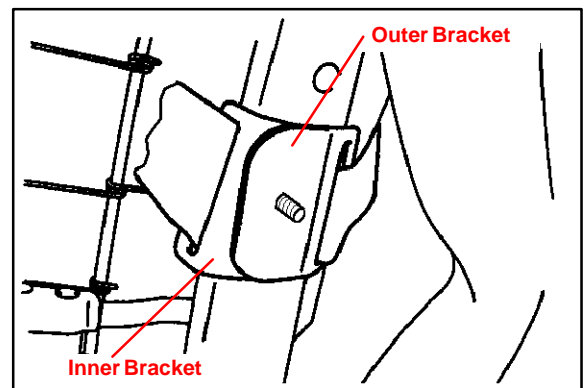

**Repair
Procedure:
Fabric Seat
(Continued)**

13. For seats equipped with side airbag:
Install and tighten the set nut.
Torque: 5.5 N-m (56 kgf-cm, 48 in.-lbf)

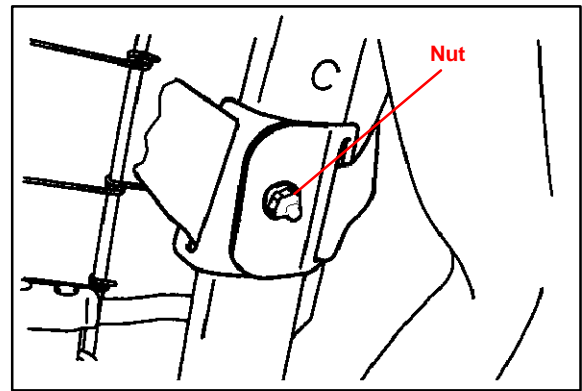

14. Pull out the front seat back pad to the bottom of the connecting rod (original position).

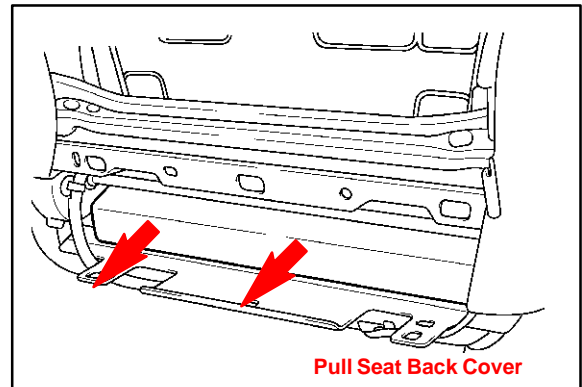

15. Place the resin plates of the seat back cover between the frame and inner cover.

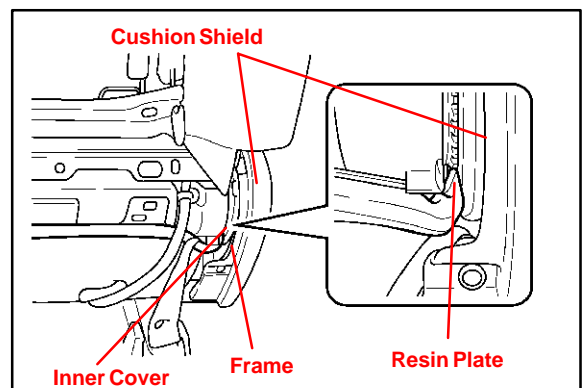

16. Pull the flap of the seat back cover up and affix it to the frame with hog rings using hog ring pliers.

NOTE:

- Be sure to use coated hog rings (90468-16019) to prevent any abnormal noise.
- Non-reusable part.

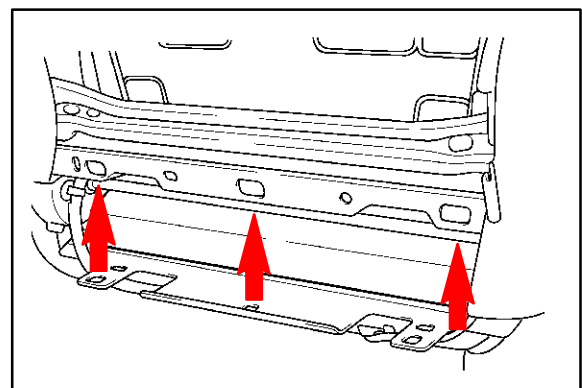

**Repair
Procedure:
Fabric Seat
(Continued)**

17. Pull out the seat back cover end at both ends of the seat back cover so that the seat back cover end does not sag and affix it to the frame with hog rings using hog ring pliers.
18. Remove the four seat track mounting bolts.
19. Zip the seat fastener, and push the end of the seat fastener between seat cover end and seat frame.
20. Lift up the seat back side of the seat.
21. Connect the two seat backboard cover rubber bands to the hooks.
22. Install the four seat track mounting bolts.

Torque: 37 N-m (375 kgf-cm, 27 ft-lbf)
23. Install the four seat track covers.
24. Install the headrest assembly.
25. Fully recline the seat back, lightly grasp the portions shown by the circles in the illustration and lightly pull in the direction of the arrow. Check that the seat back pad cannot be seen.

HINT:

If the resin plates shown in step 15 are out of position, the seat back pad can be seen during this check.

