



TOYOTA Technical Service BULLETIN

December 8, 2007

Title: **FRONT LICENSE PLATE MOUNTING BRACKET AND LICENSE PLATE INSTALLATION**

Models:
'09 Matrix

PRE-DELIVERY SERVICE
PD153-07

Introduction The front license plate mounting bracket and two self tapping screws for the 2009 model year Matrix are placed in the luggage compartment of the vehicle at the assembly plant. For states that require a front license plate, install the bracket and license plate according to the following procedures.

- Applicable Vehicles**
- **2009** model year **Matrix** vehicles.

- Installation Procedure**
1. Insert the license plate into the front license plate mounting bracket.
 2. Align the installation holes on the front license plate mounting bracket and license plate with the dimples on the front bumper.
 3. Screw the two self-tapping screws directly into the dimples to install the license plate and mounting bracket.

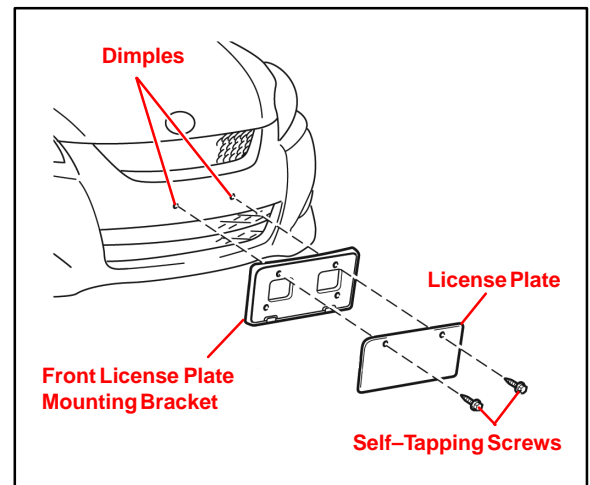

NOTE:

- Do NOT pre-drill holes in the dimples.
- Do NOT over-tighten the self-tapping screws.

Warranty Information

OP CODE	DESCRIPTION	TIME	OFF	T1	T2
N/A	Not Applicable to Warranty	-	-	-	-

