



Technical Service BULLETIN

December 1, 2000

Title: **FRONT LICENSE PLATE INSTALLATION**

Models: '01 Highlander

PRODUCT GENERAL INFORMATION
PG025-00

Introduction The following procedure is recommended for front license plate installation on the 2001 model year Highlander.

Applicable Vehicles • 2001 model year **Highlander** vehicles.

Installation Procedure 1. Align the installation holes of the front license plate with the dimples on the front bumper.

NOTE:
Do NOT pre-drill holes in the dimples.

2. Using two self-tapping screws, install the front license plate by directly screwing the self-tapping screws into the dimples.

3. Use self-tapping screws with the following dimensions:

Nominal Length (L):
20.0 mm (0.79 in.)

Diameter (D):
6.0 mm (0.24 in.)

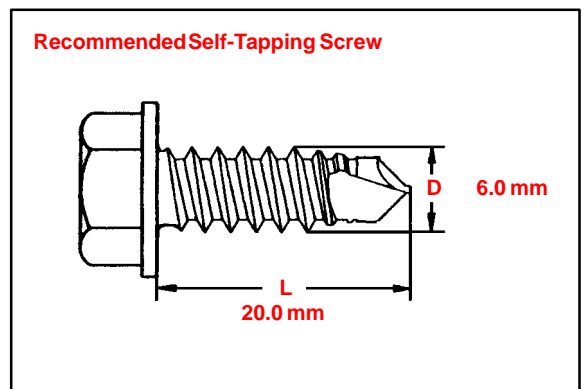
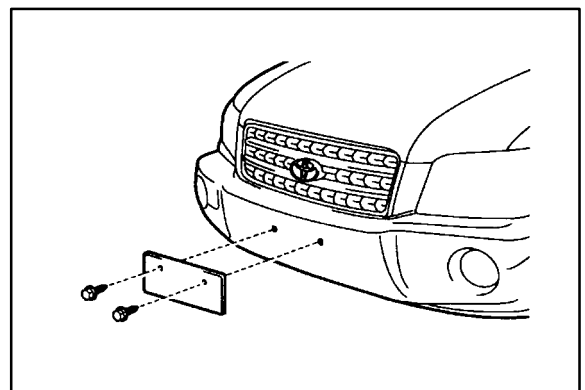

Warranty Information

OP CODE	DESCRIPTION	TIME	OPN	T1	T2
N/A	Not Applicable to Warranty	-	-	-	-

