



**Technical Service  
BULLETIN**

April 16, 1999

Title:  
**FRONT BRAKE PAD RATTLE NOISE**

Models:  
**'98 Land Cruiser**

# T S B

**BR003-99**  
**BRAKES**

**Introduction** To reduce rattle noise from front brake pads when driving over bumps or rough roads, front brake Anti-rattle Springs have been added.

**Production Change Information**

- **1998 Land Cruisers** starting with VIN **JT3HT05J\*W0025000**

**Parts Information**

PREVIOUS P/N	CURRENT P/N	PART NAME
N/A	47748-60060	Anti-rattle Spring*

\* Order 4 parts per vehicle.

**Repair Procedure** If a customer encounters front brake pad rattle noise when driving over bumps or rough roads, install Anti-rattle Springs at both the front and rear ends of the brake pads in each front caliper, as illustrated.

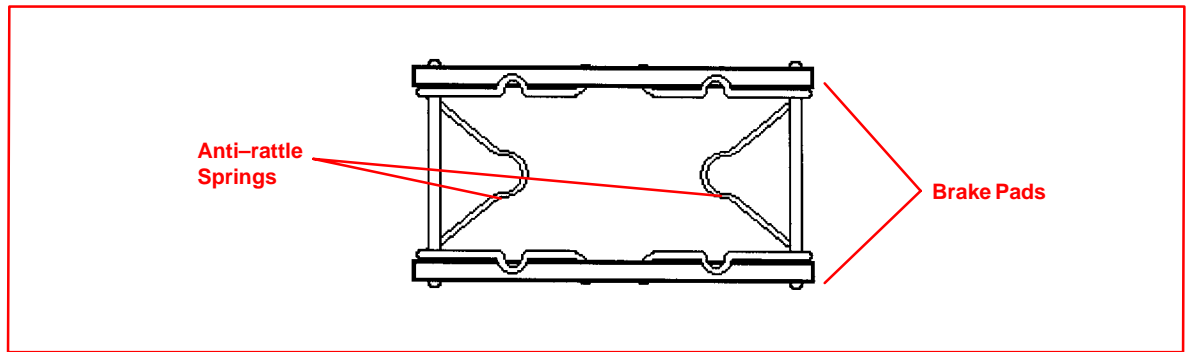

**Warranty Information**

OP CODE	DESCRIPTION	TIME	OPN	T1	T2
BR9001	Install Anti-rattle Springs	0.7	47748-60060	91	99

**Applicable Warranty\*:**

**This repair is covered under the Toyota Basic Warranty. This warranty is in effect for 36 months or 36,000 miles, whichever occurs first, from the vehicle's in-service date.**

\* Warranty application is limited to correction of a problem based upon a customer's specific complaint.

