



**Technical Service
BULLETIN**

June 28, 2007

Title:

**ENGINE BANK 1 AND BANK 2 A/F AND
O2 IDENTIFICATION**

Models:

'93 – '08 Applicable Models

**ENGINE
EG034-07**

TSB UPDATE NOTICE:

The information contained in this TSB supercedes TSB No. EG037-04.
TSB No. EG037-04 is now obsolete and should be discarded.

Introduction This service bulletin provides information on the proper identification of engine bank 1 and engine bank 2 for correct A/F sensor and oxygen sensor replacement.

This bulletin contains information that identifies engine bank 1 and engine bank 2 on the following engines: 1AZ-FE, 2AZ-FE, 2AZ-FE (PZEV), 1GR-FE, 2GR-FE, 2GR-FSE, 2JZ-GE, 1MZ-FE, 3MZ-FE, 1UR-FSE, 3UR-FE, 2UZ-FE, 3UZ-FE, 5VZ-FE, and 1ZZ-FE.

- Bank 1 (B1) refers to the bank that includes cylinder No. 1.
- Bank 2 (B2) refers to the bank opposite bank 1.
- Sensor 1 (S1) refers to the sensor that is located before the catalytic converters.
- Sensor 2 (S2) refers to the sensor that is located after the catalytic converters.

**Warranty
Information**

OP CODE	DESCRIPTION	TIME	OFF	T1	T2
N/A	Not Applicable to Warranty	-	-	-	-

**Applicable
Vehicles**

MODEL	MODEL YEAR	ENGINE
4Runner	1996 – 2002	5VZ-FE
	2003 – 2008	1GR-FE 2UZ-FE
Avalon	1995 – 2004	1MZ-FE 3MZ-FE
	2005 – 2008	2GR-FE
Camry	1994 – 2003	1MZ-FE
	2004 – 2006	1MZ-FE 3MZ-FE
	2003 – 2008	2AZ-FE PZEV
	2008	2GR-FE
FJ Cruiser	2007 – 2008	1GR-FE



Applicable Vehicles
(Continued)

MODEL	MODEL YEAR	ENGINE
Highlander	2001 – 2003	1MZ-FE 2AZ-FE
	2004 – 2007	3MZ-FE
	2008	2GR-FE
Land Cruiser	1998 – 2007	2UZ-FE
	2008	3UR-FE
MR2 Spyder	2000 – 2005	1ZZ-FE
RAV4	2001 – 2003	1AZ-FE
	2006 – 2008	2GR-FE
Sequoia	2001 – 2008	2UZ-FE
	2008	3UR-FE
Sienna	1998 – 2003	1MZ-FE
	2004 – 2006	3MZ-FE
	2007 – 2008	2GR-FE
Solara	1999 – 2003	1MZ-FE
	2004 – 2008	3MZ-FE
Supra	1993 – 1998	2JZ-GE
Tacoma	1995 – 2004	5VZ-FE
	2005 – 2008	1GR-FE
T-100	1995 – 1998	5VZ-FE
Tundra	2000 – 2004	5VZ-FE 2UZ-FE
	2005 – 2008	1GR-FE 2UZ-FE
	2007 – 2008	3UR-FE

Engine Bank Identification

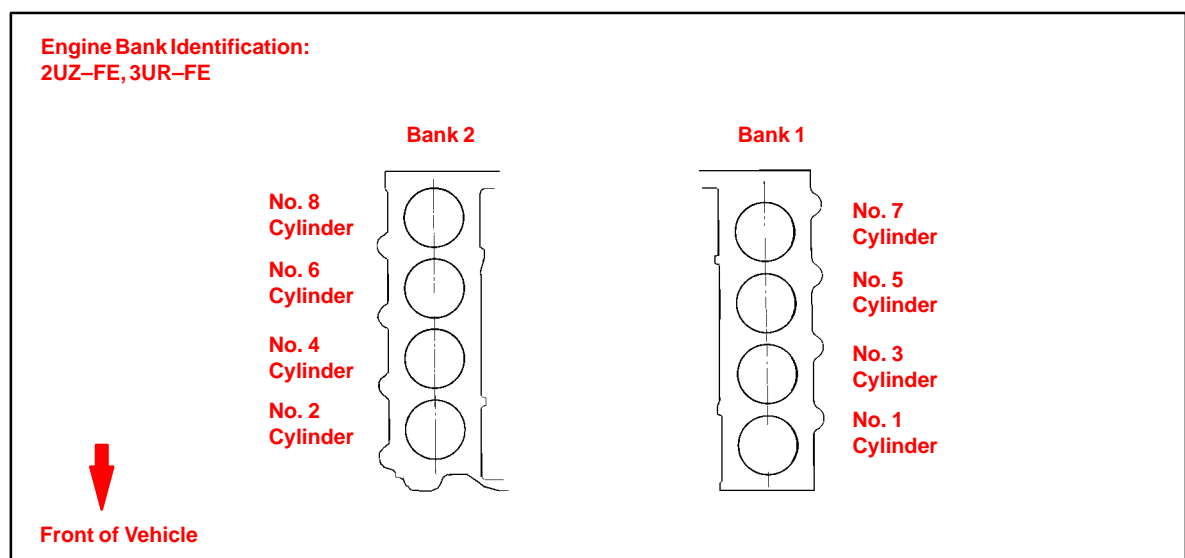

Engine Bank Identification
(Continued)

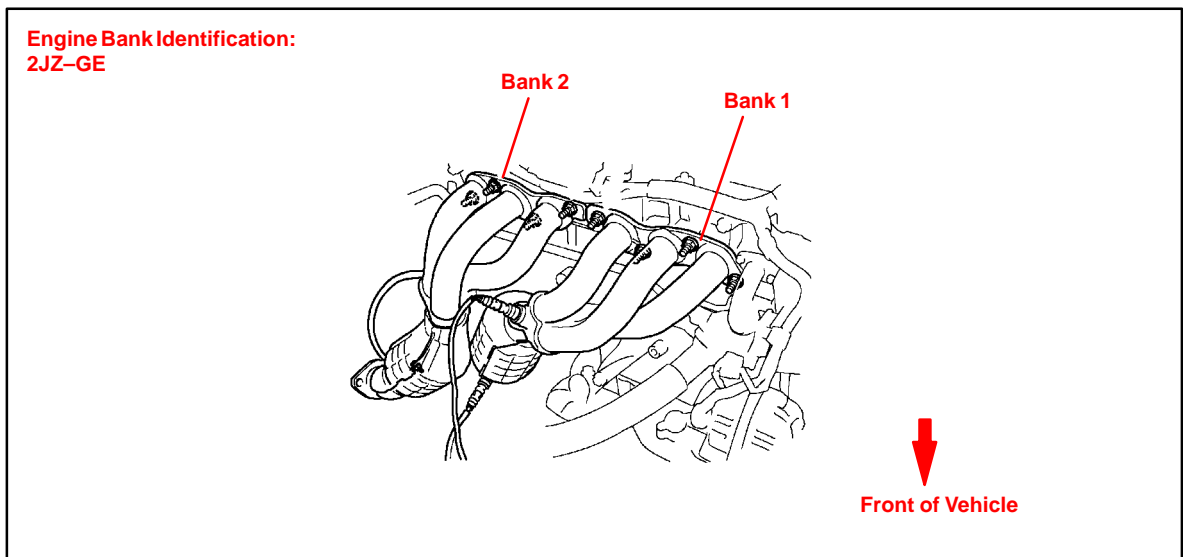
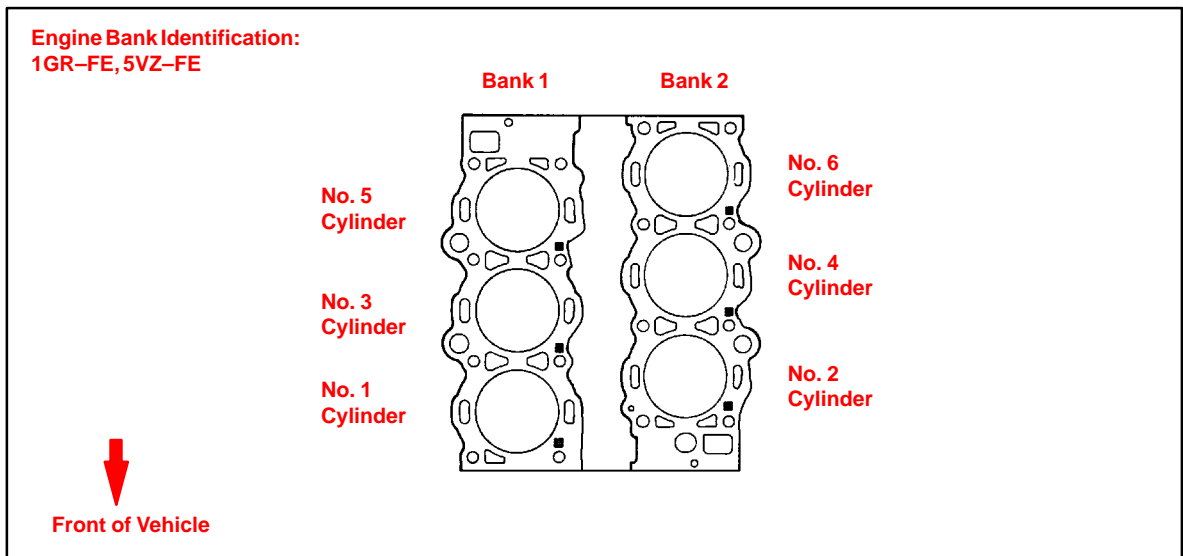
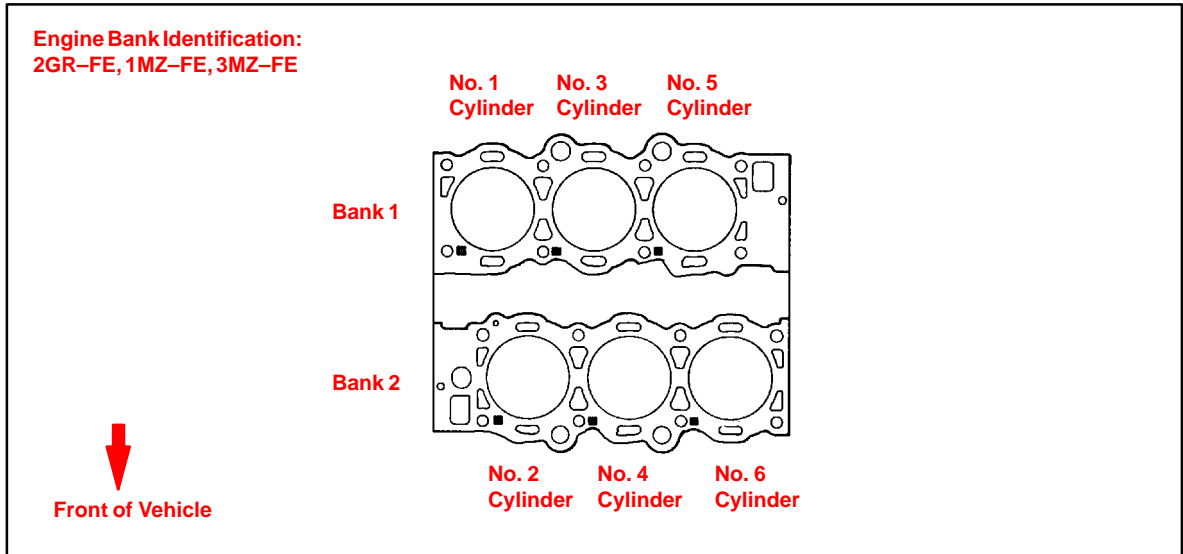

Engine Bank Identification
(Continued)

Engine Bank Identification:
1ZZ-FE

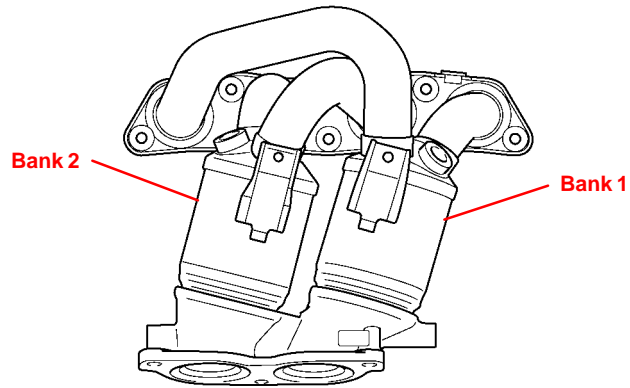

Engine Bank Identification:
1AZ-FE

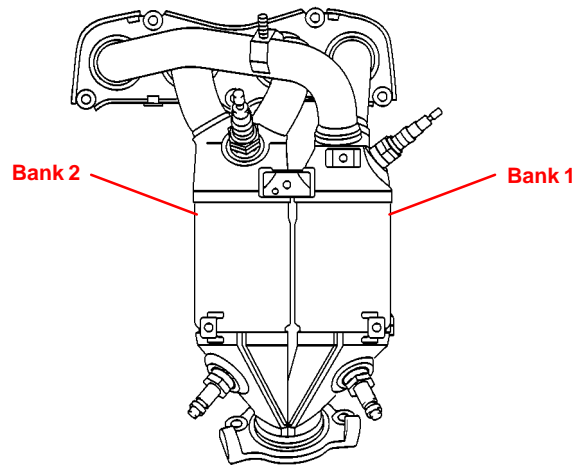

Engine Bank Identification:
2AZ-FE

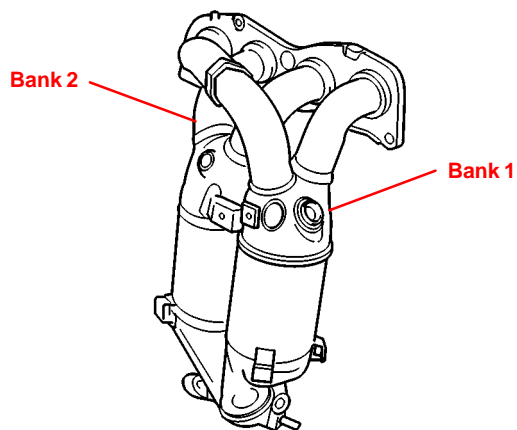

**A/F and O2
Sensor
Identification**

