

TOYOTA

SERVICE BULLETIN

TOYOTA MOTOR SALES, U.S.A., INC.

VOLUME

9

REFERENCE AUDIO
NUMBER 007
DATE 07-15-88
MODEL ALL MODELS

Page 1 of 8

AUDIO SYSTEM TROUBLESHOOTING GUIDE

The following troubleshooting guide has been developed to provide vehicle on-board diagnosis of audio related problems.

<u>SYMPTOM:</u>	<u>REFERENCE PAGE</u>
NO SOUND	2
NO PRESENT MEMORY	3
NO AUTO SEARCH	3
LOSE MEMORY	3
RADIO RECEPTION PROBLEM	4
CASSETTE WON'T ACCEPT TAPES	5
CASSETTE WON'T EJECT TAPES	5,7
CASSETTE HAS NO POWER	5
CASSETTE SOUND IS MUFFLED	6
CASSETTE EATS TAPES	7
TAPE DIRECTION SWITCHES BACK AND FORTH	7
ANTENNA WON'T GO UP	8
REMOVING CASSETTE DECK FOR SERVICE	8

AUDIO SYSTEM TROUBLESHOOTING GUIDE (CONT'D)

NO SOUND?

Check that both the **BAL** and **FADER** knobs are set at their center positions. Since the **BAL** and **FADER** knobs have a double-function feature, the customer may not know how to operate them correctly.

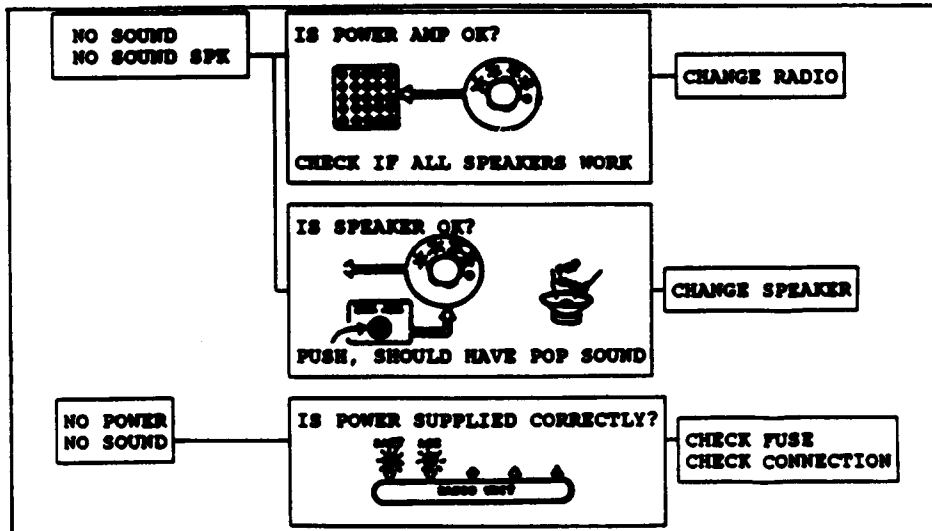
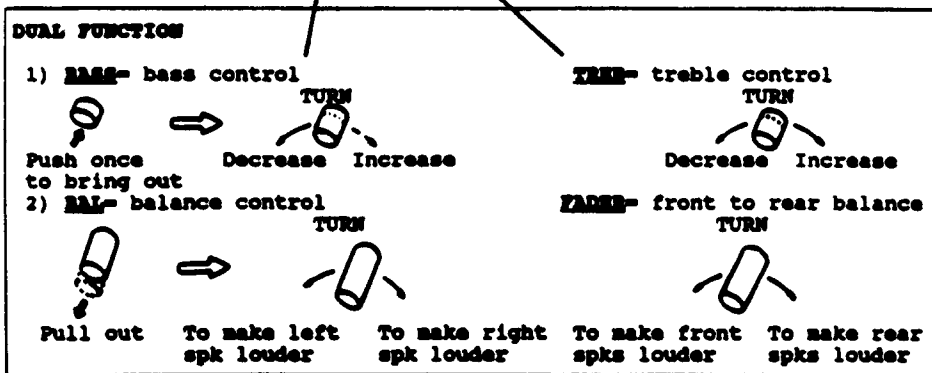
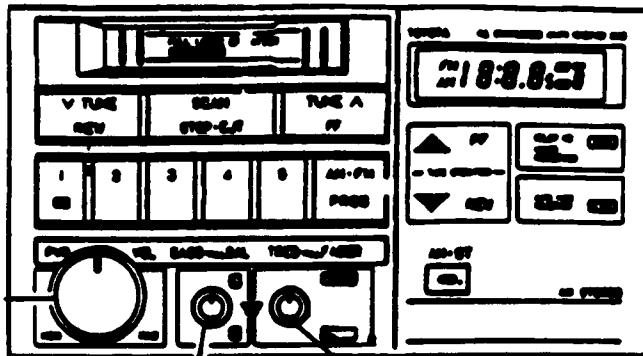

Using Radio Checker

AUDIO SYSTEM TROUBLESHOOTING GUIDE (CONT'D)

NO PRESET MEMORY? NO AUTO SEARCH?

PUSH UNTIL A BEEP SOUND IS HEARD.

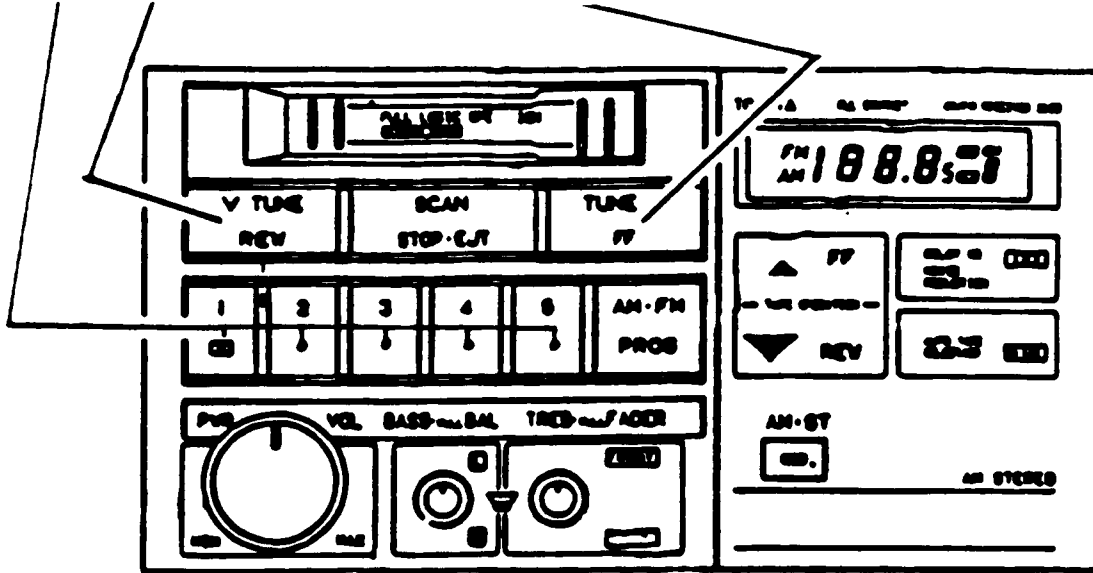

Buttons marked 1–5 for station presets (5 FM/5 AM)

How to preset stations

- 1) Tune to a desired station by manual, seek, or scan tuning.
- 2) Press any one of the preset buttons until a beep is heard. The preset's number will appear in the upper right corner of the digital display, indicating the station has been memorized.

LOSE MEMORY?

A weak battery may be the cause of the LOST MEMORY.

AUDIO SYSTEM TROUBLESHOOTING GUIDE (CONT'D)

RADIO RECEPTION PROBLEM?

STATIC, FADING OUT, NO SEARCH STOP

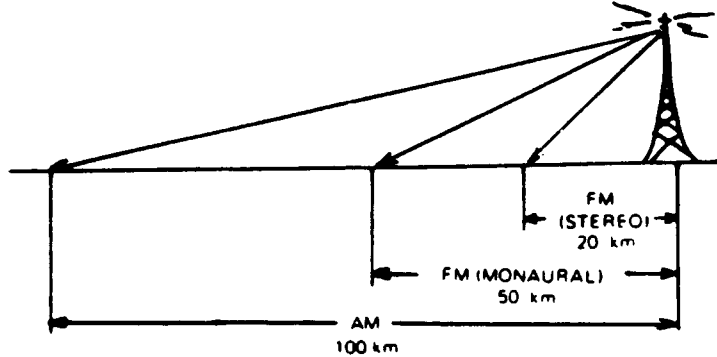

MULTIPATH NOISE

Because of the reflecting characteristics of FM signal like light, direct and reflected signals may reach the car antenna at the same time, which is so called "multipath effect". Sometimes they cancel each other out, causing dead spots. As the car moves through these spots, the listener will hear a noisy sound or fluctuation of sound. This is the same characteristics with so called "ghost" images on TV screen when reflections of TV waves are existing.

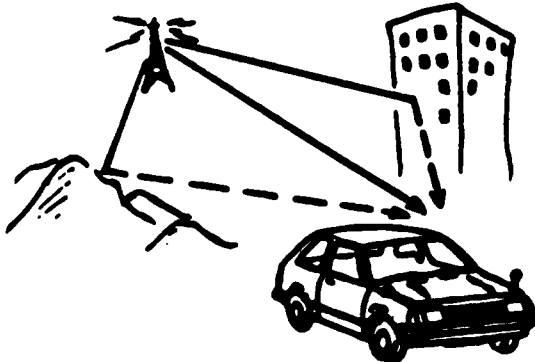

FADING OUT

1. Fading out of FM signals caused by moving a car.

In weak signal or "fringe" areas, FM stations may fade out completely or fade in and out. When driving in weak signal areas, such as hills, valleys, tunnels, etc., unusual noise interference may come up. Pull the antenna up to the full length.

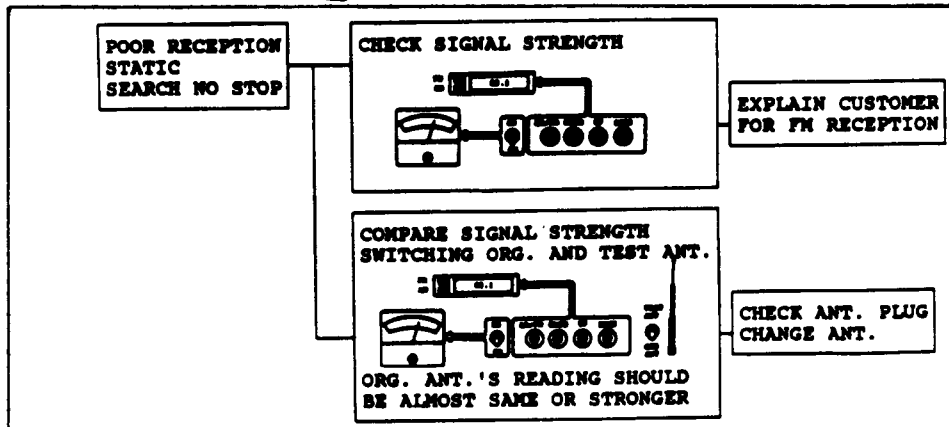
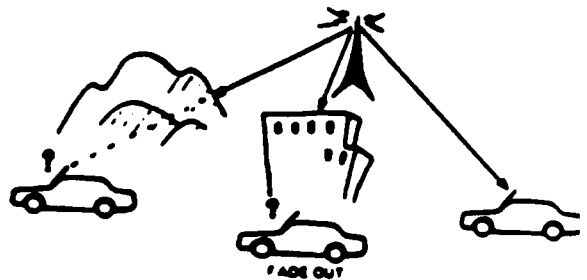

AUDIO SYSTEM TROUBLESHOOTING GUIDE (CONT'D)

**CASSETTE WON'T ACCEPT TAPES?
CASSETTE WON'T EJECT TAPES?
CASSETTE HAS NO POWER?**

RESET PROCEDURE

If you have....

NO EJECT, NO POWER, WON'T ACCEPT TAPE,

STUCK ON ONE FUNCTION problem,

RESET THE RADIO!!!

BEFORE YOU REMOVE IT!!!

PROCEDURE

Disconnect the battery's negative terminal cable,
wait thirty seconds, then reconnect.

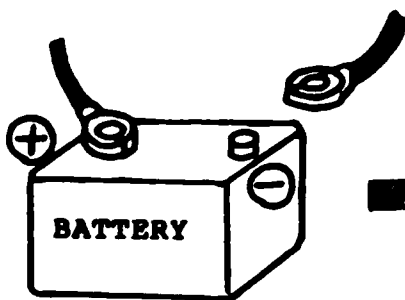

**REMOVE NEGATIVE
TERMINAL**



**WAIT FOR
30 SEC.**

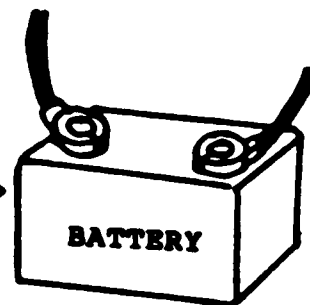

RECONNECT TERMINAL

AUDIO SYSTEM TROUBLESHOOTING GUIDE (CONT'D)

CASSETTE SOUND IS MUFFLED?

CLEAN HEAD!

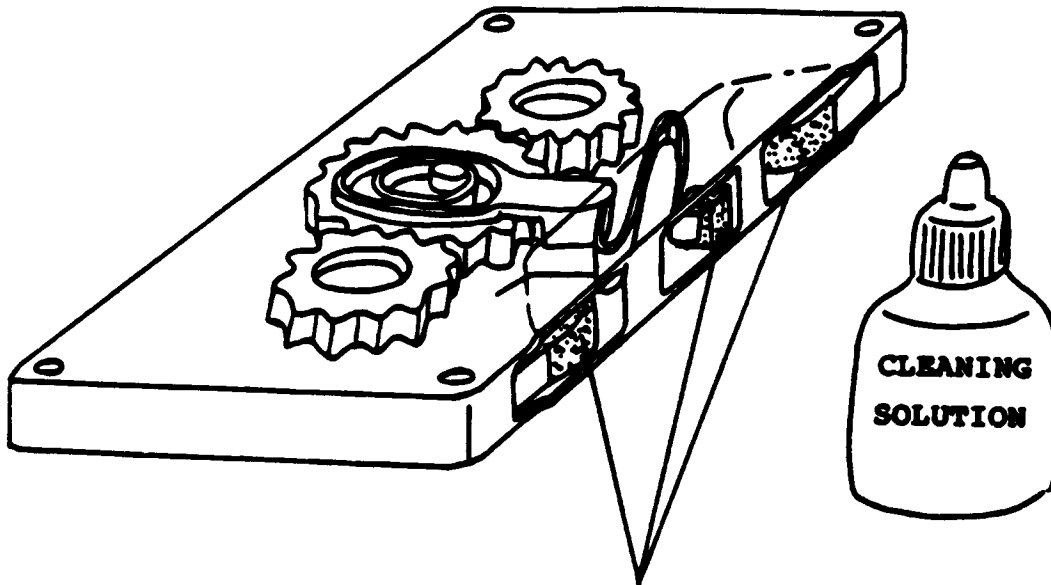

CLEANING PADS

THIS KIND OF HEAD CLEANER IS RECOMMENDED.

Clean your head! Use a good quality tape head cleaner regularly to keep the deck from getting dirty or gummed up. Depending on the use your tape player gets, one cleaning per 15 hours of tape play should be sufficient.

AUDIO SYSTEM TROUBLESHOOTING GUIDE (CONT'D)

**CASSETTE WON'T EJECT TAPES?
CASSETTE EATS TAPES?
TAPE DIRECTION BACK AND FORTH?**

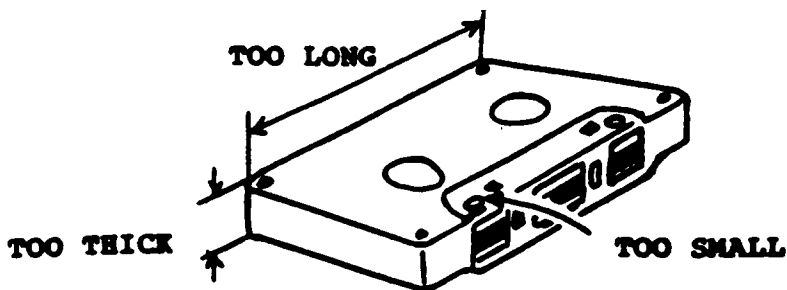

Use good quality tape. There are some tapes which shells are not standard size.

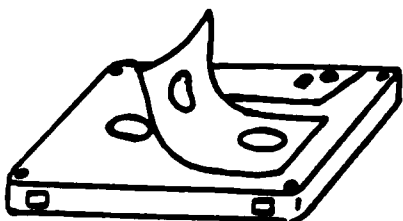

PEELING LABEL

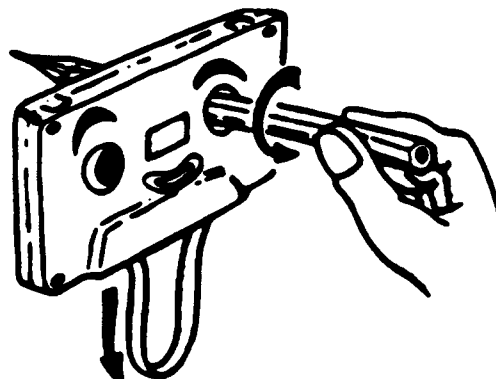

Wind loose tape back into the cassette

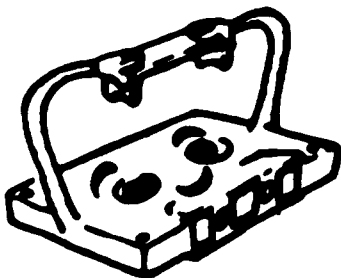

REMOVE CLAMP

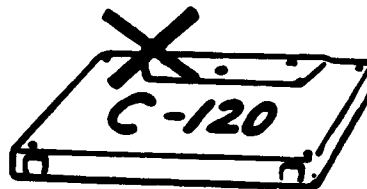

DO NOT USE 120 MIN. TAPES

IF TAPE REMAINS STUCK, TRY RESET PROCEDURE, THEN TAKE THE UNIT FOR SERVICE. DO NOT TRY TO PRY OUT THE TAPE!!

AUDIO SYSTEM TROUBLESHOOTING GUIDE (CONT'D)

To avoid damaging the plug when removing the cassette for service,

REMOVING CASSETTE DECK FOR SERVICE

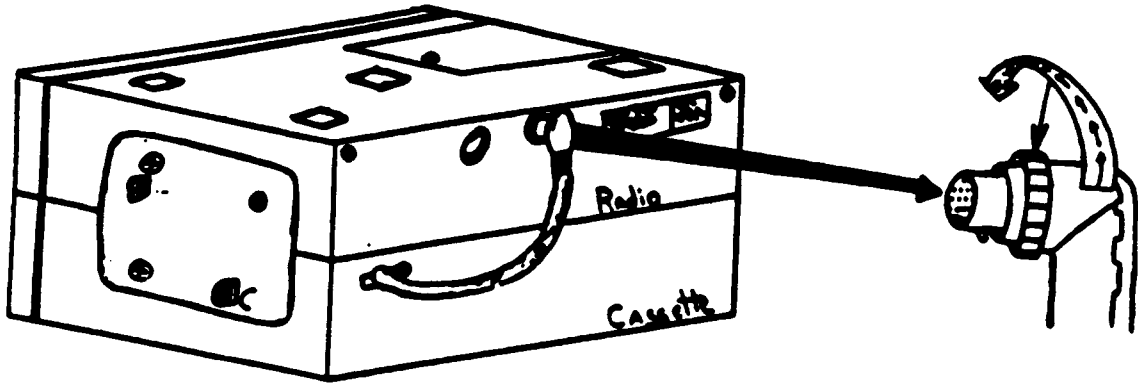

TURN THE RING ON THE PLUG AS ILLUSTRATED,
THEN PULL IT STRAIGHT OUT!!!

ANTENNA WON'T GO UP?

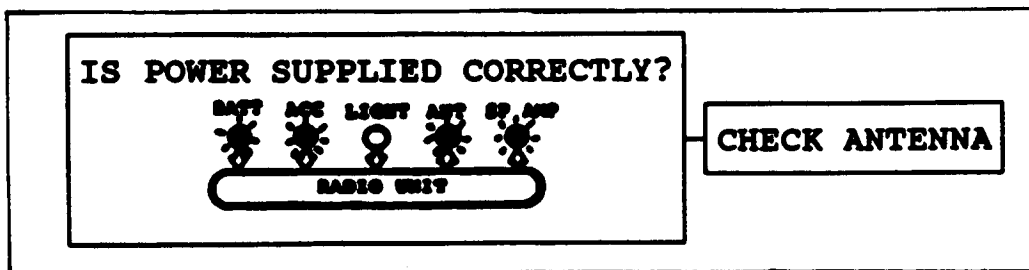

Using Radio Checker