



Technical Service BULLETIN

February 13, 1998

Title: 3VZ CYLINDER HEAD INSTALLATION

Models: '88 – '95 V6 Truck, 4Runner & T100

ENGINE
EG002-98

Introduction 3VZ cylinder head bolts are reusable. To prevent unnecessary replacement of cylinder head bolts, the following procedures must be followed during cylinder head installation.

Affected Vehicles • 1988 through 1995 Trucks, 4Runners and T100s equipped with the 3VZ V6 engine.

Warranty Information

OP CODE	DESCRIPTION	TIME	OPN	T1	T2
N/A	No Applicable to Warranty Information	–	–	–	–

Procedure The Cylinder head bolts are tightened in three progressive steps:

1. Install cylinder head
 - a. Place a new cylinder head gasket on the engine block and install cylinder head.
 - b. Apply a light coat of engine oil on the threads and washer face of the cylinder head bolts.
 - c. Install the plate washer to the cylinder head bolt.
 - d. Using a 12-point socket, install and uniformly tighten the (8) 12-point bolts in the sequence shown in the illustration.

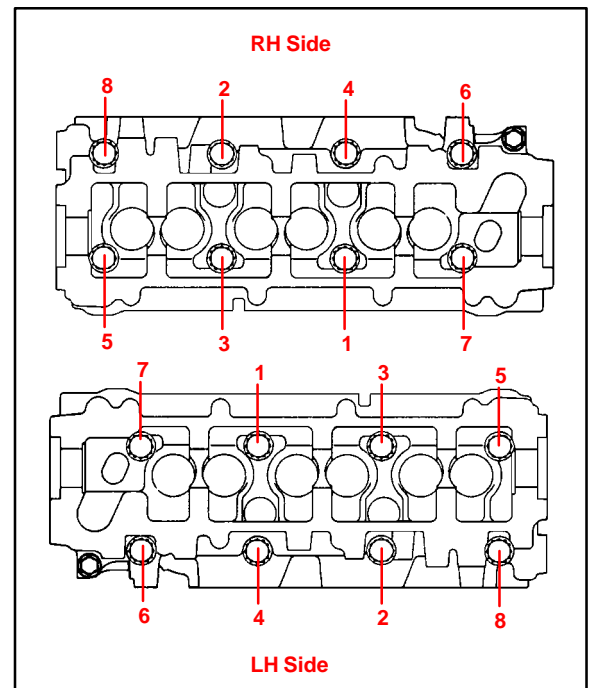

Torque: 33 ft.lbs. (44 N-m, 450 kg-cm)

- e. Repeat for the other head.
2. Proceed with final tightening sequences:
 - a. Mark the front side of the top of the bolt with a drop of paint as shown in the illustration.

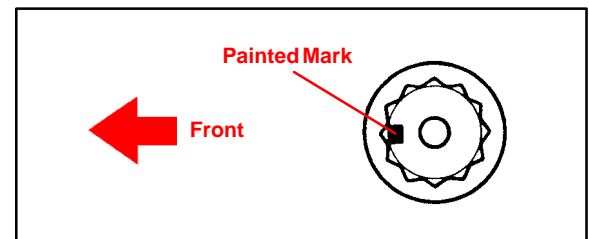

Procedure
(Continued)

- b. Uniformly torque the bolts an additional 90 degrees following the same sequence as before.
- c. Check that the painted mark is now facing sideways.

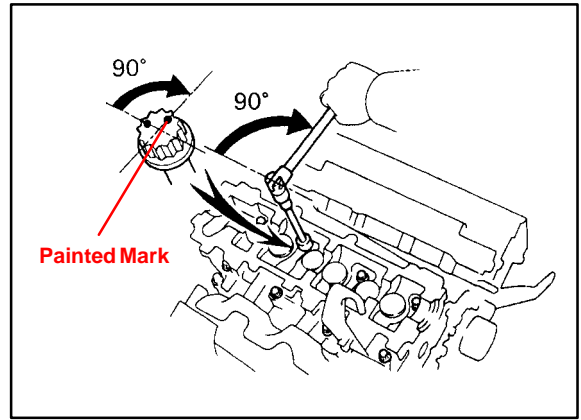

- d. Uniformly torque the bolts an additional 90 degrees again using the same tightening sequence.
- e. Check that the painted mark is now facing rearward.

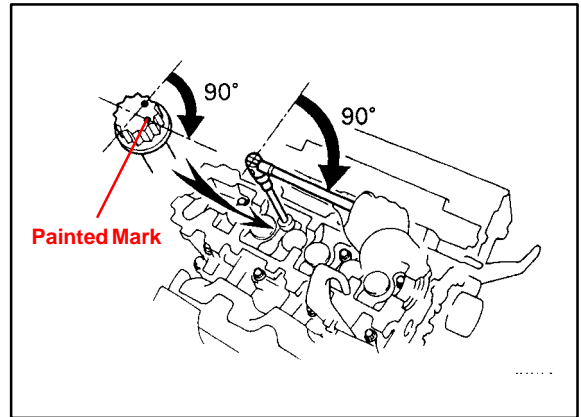

IMPORTANT:
IF ANY ONE OF THE BOLTS DOES NOT MEET THE TORQUE SPECIFICATION, REPLACE ONLY THAT BOLT. IT IS NOT NECESSARY TO REPLACE BOLTS IN SETS. ONLY THE BOLT(S) THAT DO NOT MEET THE TORQUE SPECIFICATION SHOULD BE REPLACED.

- 3. Apply a light coat of engine oil on the threads and washer face of the hex type cylinder head bolts. Install and torque the hex type head bolts to each cylinder head.

Torque: 30 ft.lbs. (41 N–m, 420 kg–cm)

