

TOYOTA

SERVICE BULLETIN

TOYOTA MOTOR SALES, U.S.A., INC.

VOLUME

9

REFERENCE ENGINE _____

NUMBER 028

DATE 09-30-88

MODEL RN (22R ENG.)

Page 1 of 2

22R ENGINE THERMOSTAT REVISION

To increase the durability of the thermostat on the 22R engines, the following changes have been made: (see figure 1 below)

1. The number of O-ring seals for the piston has been increased from one to two.
2. The metal guide has been replaced by a rubber sleeve.

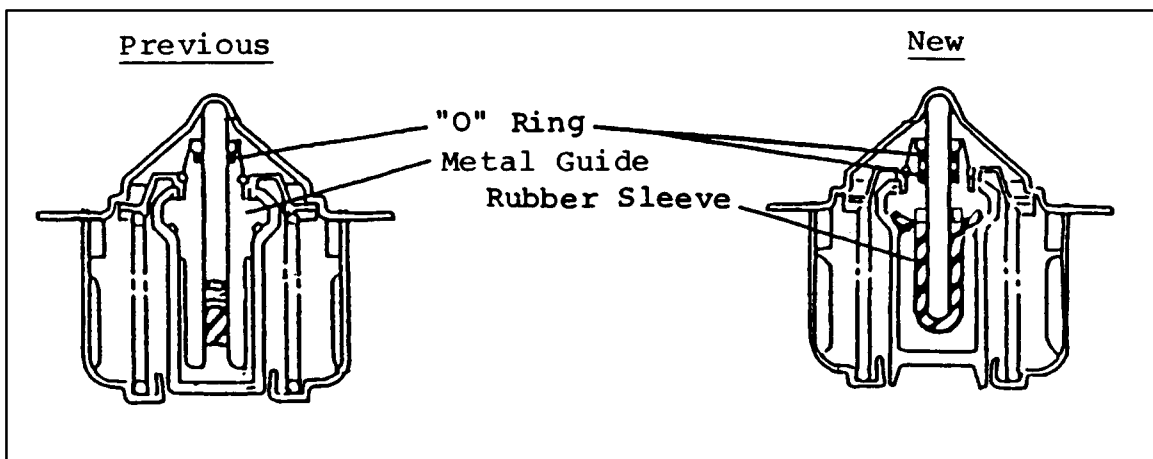

Figure 1

PRODUCTION EFFECTIVE:

From Engine Number
22R-2389180

Production Date
October, 1987

PART NUMBER INFORMATION:

The part number remains unchanged:

PART NAME	PART NO.
Thermostat	90916-03078

22R THERMOSTAT REVISION (cont'd)

REVISED PART IDENTIFICATION:

To identify a new design thermostat, read the date code stamped on the thermostat (refer to Figure 2 for location).

<u>Date Code</u>	<u>Production Date</u>
87J	Oct 1987
87K	Nov 1987
87L	Dec 1987
88A	Jan 1988
88B	Feb 1988

The production change was implemented in mid-October 1987, therefore all thermostats with a date code of 87K or newer are the new design.

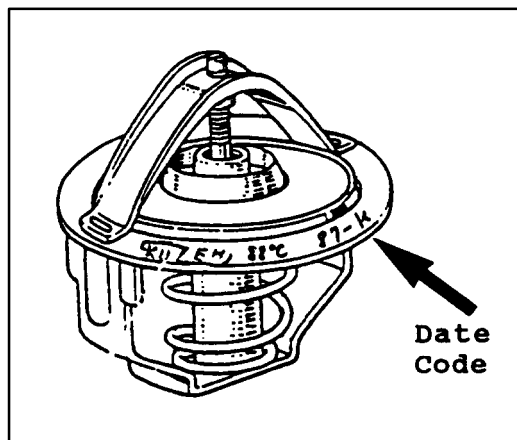

Figure 2