

# Front License Plate Installation During PDS

**Service Category** General

**Section** Pre-Delivery Service

**Market** USA

Toyota Supports ASE Certification

## Applicability

YEAR(S)	MODEL(S)	ADDITIONAL INFORMATION
2010	FJ Cruiser	

## Introduction

Follow the procedure below to install the front license plate on 2010 model year FJ Cruiser vehicles during Pre-Delivery Service (PDS).

## Parts Information

PREVIOUS PART NUMBER	CURRENT PART NUMBER	PART NAME	QTY
00473-00001	Same	Kit, Self-tapping Screw	1

## Warranty Information

OP CODE	DESCRIPTION	TIME	OPF	T1	T2
N/A	Not Applicable to Warranty	-	-	-	-

## Installation Procedure

1. Attach the two (2) rubber seats along the bottom edge and 20 mm (0.79 in.) away from the side edges on the backside of the front license plate.

**NOTE**

- The two (2) rubber seats are loaded in the glove box.
- The rubber seats should NOT extend over the bottom edge of the front license plate.

**Figure 1. Backside of Front License Plate**

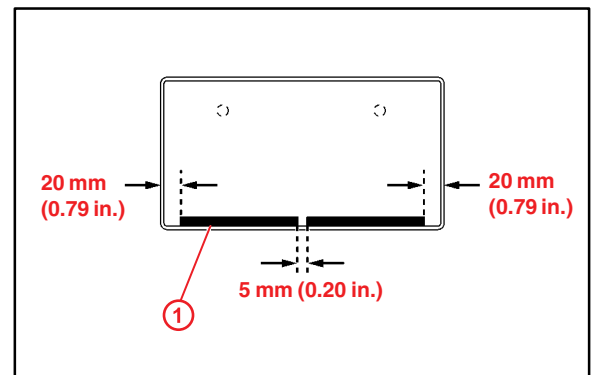

<b>1</b>	<b>Rubber Seat</b>
----------	--------------------

## Front License Plate Installation During PDS

### Installation Procedure (Continued)

- Align the installation holes of the front license plate with the dimples of the front bumper.

**Figure 2.**

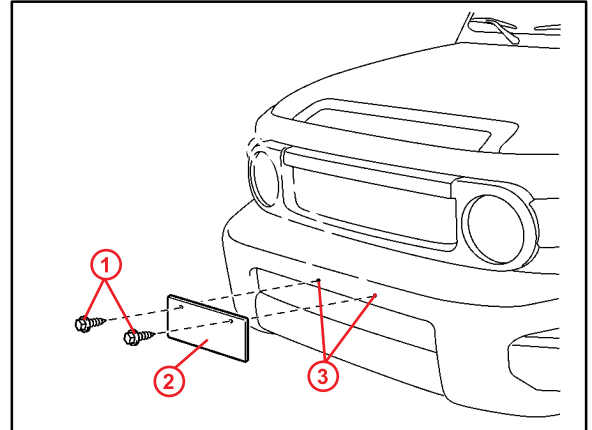

<b>1</b>	<b>Tapping Screws</b>
<b>2</b>	<b>License Plate</b>
<b>3</b>	<b>Dimples</b>

- Install two (2) self-tapping screws through the license plate and into the front bumper at the dimples.

**NOTE**

- Do **NOT** drill holes into the bumper.
- Do **NOT** overtighten the screws.

Use non-corroding self-tapping screws with the following dimensions:

**Nominal Length: 15.0 – 20.0 mm**  
**(0.59 – 0.79 in.)**  
**Diameter: 6.0 mm (0.24 in.)**

**Figure 3.**

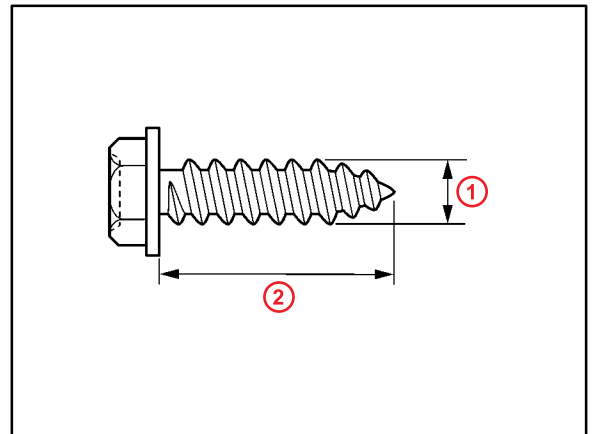

<b>1</b>	<b>Diameter</b>
<b>2</b>	<b>Nominal Length</b>