

Preparation

Part Number: PT791-04050

Kit Contents

Item #	Quantity Req'd.	Description
1	1	Hitch Center Section
2	1	LH Frame bracket
3	1	RH Frame Bracket
4	2	Auxiliary Bracket

Hardware Bag Contents

Item #	Quantity Req'd.	Description
1	6	Hex Head Bolt, M12 x 1.2 (black)
2	6	Nut, Flange, M12 x 1.2 (black)
3	8	Flange Head Bolt, M12 x 1.2
4	2	Bolt, M14 x 1.5
5	2	Nut, M14 x 1.5
6	2	Bolt Head Caps
7	1	Hitch Plug
8	6	Lock Washers

Additional Items Required For Installation

Item #	Quantity Req'd.	Description
1		
2		

Conflicts

X-Runner

Recommended Tools

Personal & Vehicle Protection	Notes
Safety Glasses	
Vehicle Protection	Cloth/Rag
Special Tools	Notes
None	
Installation Tools	Notes
Ratchet	3/8" Drive
Socket	19 mm (deep well), 17 mm, 12 mm
Socket Extension	4"
Wrench	19 mm/17 mm/12 mm
Torque Wrench	
Nylon Panel Removal Tool	e.g. Panel Pry Tool #1 Toyota SST #00002-06001-01
Special Chemicals	Notes
None	

NOTE: Part number of this accessory may not be the same as the part number shown.

General Applicability

Toyota Tacoma Trucks without a Hitch

Recommended Sequence of Application

Item #	Accessory
1	Hitch
2	Wire Harness
3	

*Mandatory

Vehicle Service Parts (may be required for reassembly)

Item #	Quantity Req'd.	Description
1	1	Bolt (P/N 90119-A0192)
2		
3		

Legend

 **STOP:** Damage to the vehicle may occur. Do not proceed until process has been complied with.

 **OPERATOR SAFETY:** Use caution to avoid risk of injury.

 **CAUTION:** A process that must be carefully observed in order to reduce the risk of damage to the accessory/vehicle and to ensure a quality installation.

 **TOOLS & EQUIPMENT:** Used in Figures calls out the specific tools and equipment recommended for this process.

Care must be taken when installing this accessory to ensure damage does not occur to the vehicle. The installation of this accessory should follow approved guidelines to ensure a quality installation.

These guidelines can be found in the "Accessory Installation Practices" document.

This document covers such items as:-

- Vehicle Protection (use of covers and blankets, cleaning chemicals, etc.).
- Safety (eye protection, rechecking torque procedure, etc.).
- Vehicle Disassembly/Reassembly (panel removal, part storage, etc.).
- Electrical Component Disassembly/Reassembly (battery disconnection, connector removal, etc.).

Please see your Toyota dealer for a copy of this document.

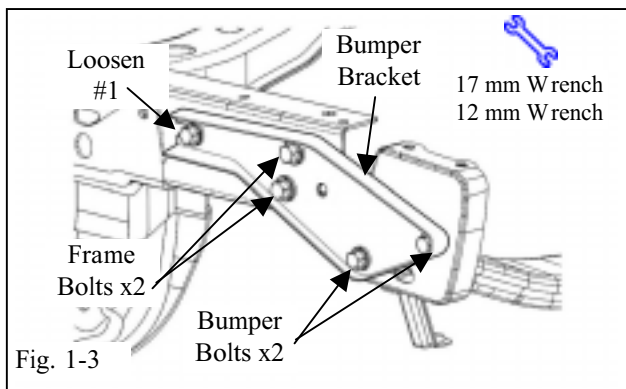
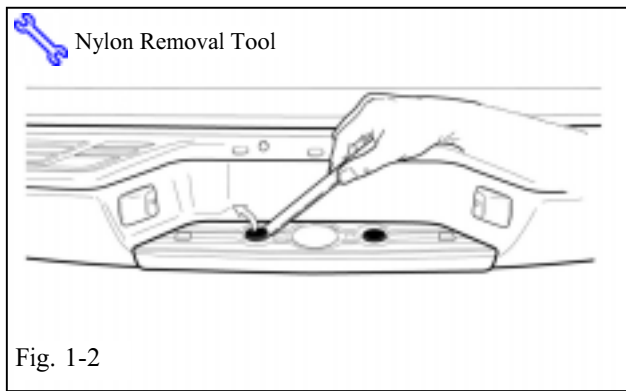
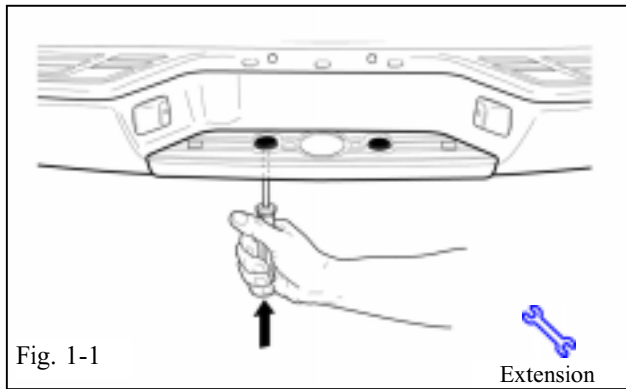

1. Installation of Hitch.



- (a) Wear safety glasses.
- (b) Caution muffler may be hot.
- (c) Using a socket extension, push the two plastic covers up. (Fig. 1-1)
- (d) Using a nylon trim removal tool, remove and discard the two plastic covers. (Fig. 1-2)
- (e) Lift vehicle and support the bumper assembly.
- (f) Remove the existing bumper bracket on the driver's side. Only loosen bolt #1. (Fig. 1-3)
 - (1) Remove and retain the two bolts attaching the bumper bracket to the bumper and the two rear bolts into the frame.
 - (2) Replace any bolts with damaged threads. (P/N 90119-A0192)
 - (3) Pull the bracket away from the frame and discard.

NOTE: For clarity the bumper cover is not shown on Figs 1-3 through 2-1.

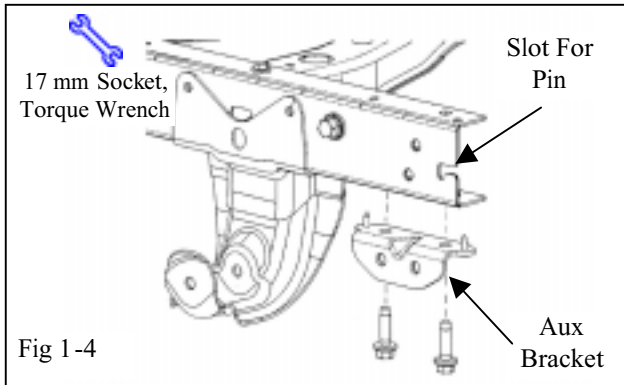

(g) Attach the auxiliary bracket to the bottom of the frame with two supplied M12 flange bolts. Tighten bolts to 45 N-m (33 lbf-ft.) (Fig. 1-4)

(h) Align the pin on the driver side bracket with the pin slot in the frame. Attach the bracket to the frame and bumper using the four M12 bolts removed in step 1. (f) 1. Hand tighten the hardware. (Fig. 1-5)

(i) Attach driver side bracket to auxiliary bracket using two supplied M12 flange bolts. (Fig. 1-5)

(j) Repeat steps 1. (f) through 1. (i) for the passenger side.

(k) Raise hitch center section into position.

(1) Place three supplied black M12 hex head bolts with lock washers through the brackets on driver and passenger side of the hitch center section and through the side brackets. (Fig. 1-6)

(2) Hand tighten supplied flange nuts onto the black M12 hex head bolts.



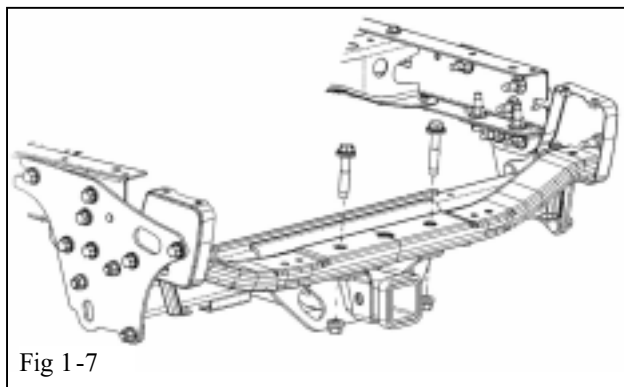
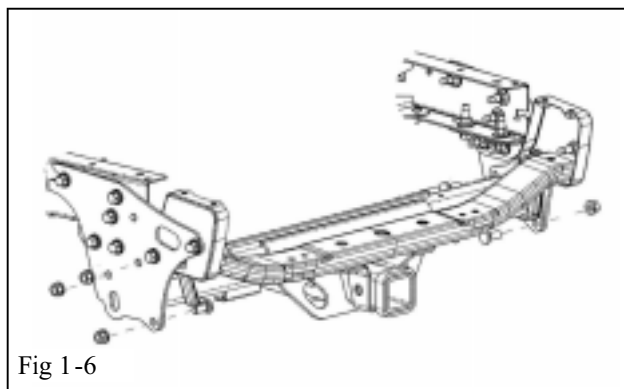
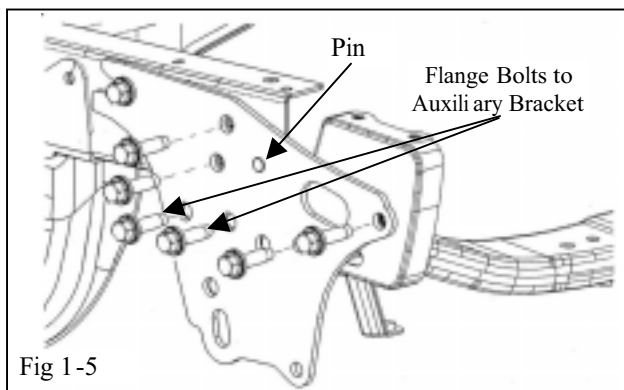

(3) Place two supplied M14 bolts through holes in top of bumper and through flanges on hitch box. (Fig. 1-7).

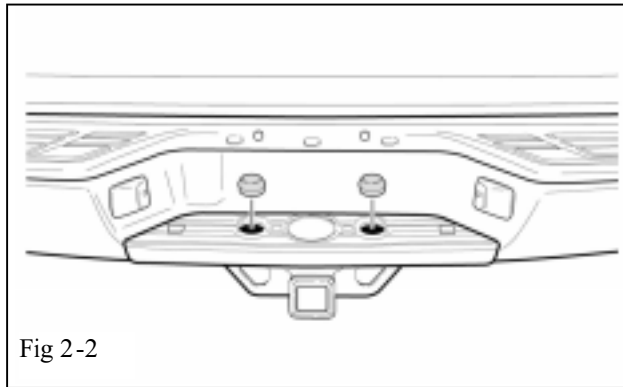
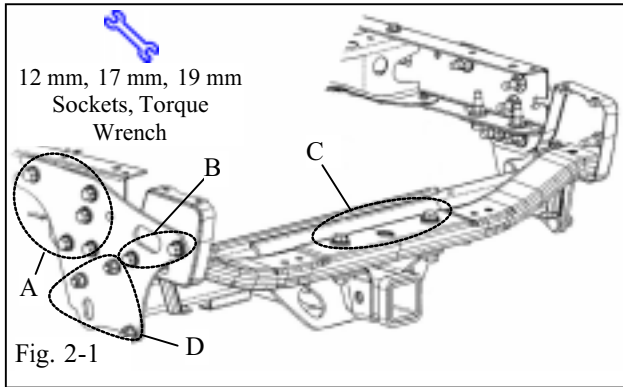
(4) Hand tighten supplied M14 flange nuts onto M14 bolts extending through hitch box flanges. (Fig. 1-7)





2. Complete Installation.

-  (a) Group A - Tighten M12 bolts on side of auxiliary bracket followed by M12 bolts in frame to 90 N-m (66 lbf-ft). (Fig. 2-1)
-  (b) Group B - Tighten M12 bolts in bumper to 65 N-m (48 lbf-ft). (Fig 2-1)
-  (c) Group C - Tighten M14 bolts to 90 N-m (66 lbf-ft). (Fig 2-1)
-  (d) Group D - Tighten black M12 bolts connecting hitch center section to 90 N-m (66 lbf-ft). (Fig 2-1)
- (e) Check Hitch and Bumper Alignment to Body to ensure even gap.
- (f) Use domed caps to cover M14 bolt heads on bumper. (Fig 2-2)
- (g) Lower vehicle.

3. Hitch Plug.

-  (a) Place hitch plug in glove box.

Checklist - these points **MUST** be checked to ensure a quality installation.

Check:

Accessory Function Checks



Bolt Torque Inspection

Hitch Plug

Look For:

Tightening torques have a range of:

Side bracket to frame, auxiliary bracket and hitch: - (M12) 72 N-m (53 lbf-ft) - 108 N-m (80 lbf-ft)

Side bracket to bumper: - (M12) 52 N-m (38 lbf-ft) - 78 N-m (58 lbf-ft)

Auxiliary bracket to frame: - (M12) 36 N-m (27 lbf-ft) - 54 N-m (40 lbf-ft)

Bumper to tow hitch: - (M14) 72 N-m (53 lbf-ft) - 108 N-m (80 lbf-ft)

Placed in Glove Box