

**Part Number: PT278-35050**

**Kit Contents**

Item #	Quantity Reqd.	Description
1	1	LH Base Rail Assembly w/xbar
2	1	RH Base Rail Assembly
3	1	Hardware Bag
4	2	Brackets
5	1	Front Crossbar Assembly

**Hardware Bag Contents**

Item #	Quantity Reqd.	Description
1	8	M6 x 14mm Wafer HD Screws
2	6	M6 x 35mm Button HD Screws
4	1	Instruction Sheet
5	1	Operator Caution Card
6	1	Hinge Screw
7	10	Mastic Washers

**Additional Items Required For Installation**

Item #	Quantity Reqd.	Description
1		
2		

**Conflicts**

--

**Recommended Tools**

<b>Personal &amp; Vehicle Protection</b>	<b>Notes</b>
Safety Goggles	
Wrist & Belt Buckle Protectors	
<b>Special Tools</b>	<b>Notes</b>
None	
<b>Installation Tools</b>	<b>Notes</b>
T25 Torx Driver (High Quality; Hardened)	i.e.; Snap-on, Mac, etc
Torque Wrench	0-150 lbf-in
Awl	
X-Acto Knife, Deburring Tool, or equivalent	
Nylon Panel Removal Tool	e.g. Panel Pry Tool #1 Toyota SST# 00002-06001-01
<b>Special Chemicals</b>	<b>Notes</b>
None	

**General Applicability**

All D-Cab Tacoma Models
-------------------------

**NOTE:** Part number of this accessory may not be the same as the part number shown.

**Recommended Sequence of Application**





Item #	Accessory
1	
2	
3	

\*Mandatory

**Vehicle Service Parts** (may be required for reassembly)

Item #	Quantity Reqd.	Description
1		
2		
3		

**Legend**

	<b>STOP:</b> Damage to the vehicle may occur. Do not proceed until process has been complied with.
	<b>OPERATOR SAFETY:</b> Use caution to avoid risk of injury.
	<b>CAUTION:</b> A process that must be carefully observed in order to reduce the risk of damage to the accessory/vehicle and to ensure a quality installation.
	<b>TOOLS &amp; EQUIPMENT:</b> Used in Figures calls out the specific tools and equipment recommended for this process.

Care must be taken when installing this accessory to ensure damage does not occur to the vehicle. The installation of this accessory should follow approved guidelines to ensure a quality installation.

These guidelines can be found in the "Accessory Installation Practices" document.

This document covers such items as:-

- Vehicle Protection (use of covers and blankets, cleaning chemicals, etc.).
- Safety (eye protection, rechecking torque procedure, etc.).
- Vehicle Disassembly/Reassembly (panel removal, part storage, etc.).
- Electrical Component Disassembly/Reassembly (battery disconnection, connector removal, etc.).

Please see your Toyota dealer for a copy of this document.

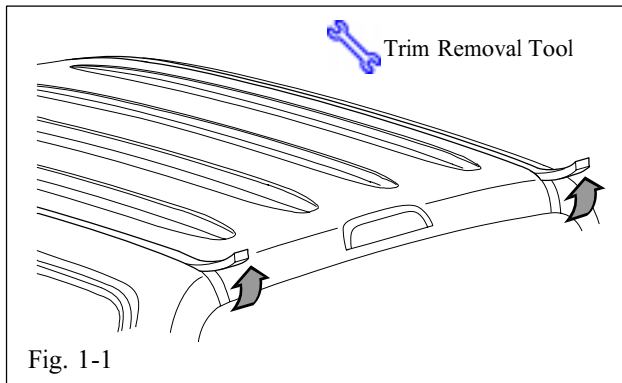

**1. Remove Ditch Moldings.**



(a) Carefully remove the ditch moldings from both sides of vehicle. (Fig. 1-1)

(b) Discard the roof ditch moldings.



(c) Carefully remove any remaining tape residue at rear of ditch above rear window.

(d) Using trim removal tool, break off vertical walls of front ditch clips (RH & LH). Wedge trim removal tool in from outside then give it a sharp blow with your hand. This should cause the wall to break. Repeat for both sides. (Fig. 1-2)

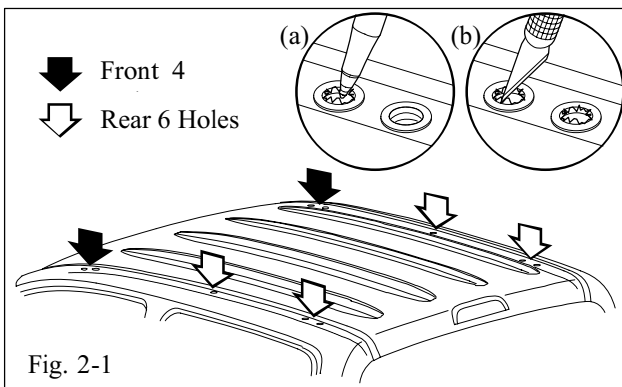
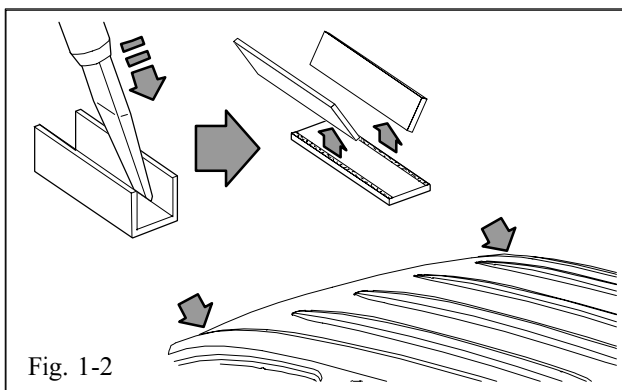

**2. Prepare Roof for Rack Installation.**

(a) Puncture tape that covers the 10 weldnuts (5 RH & 5 LH) with a ball point pen. (Fig. 2-1)



(b) Using an X-Acto knife or deburring tool, carefully remove all seal material in the FRONT 4 HOLES ONLY (2 RH & 2 LH) so that the weld nut is visible and no seal material is down near the threads. (Fig. 2-1)

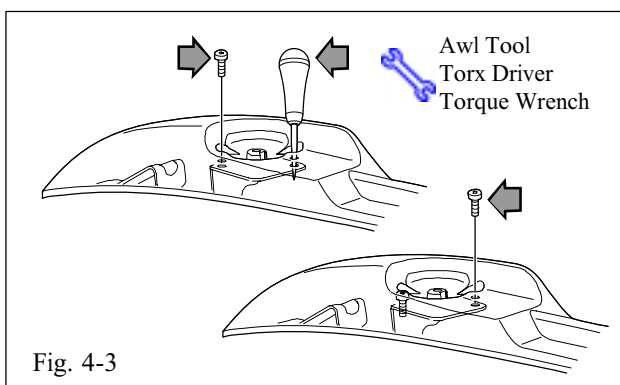
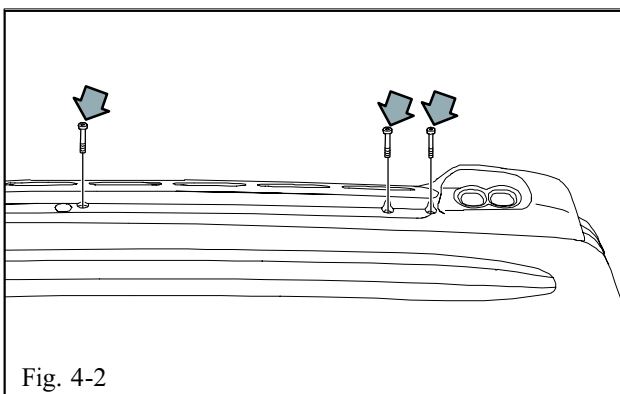
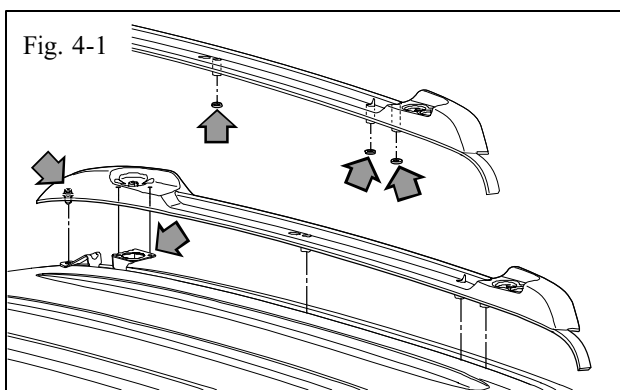
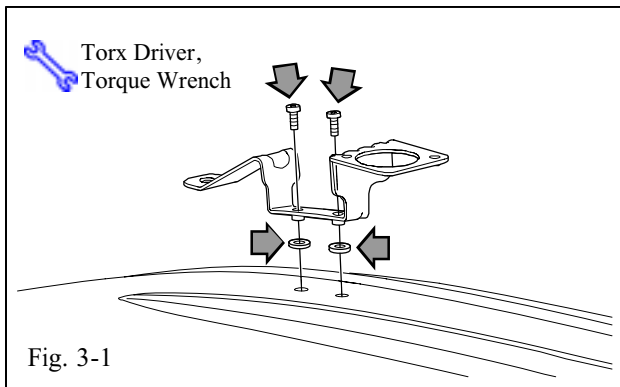

### 3. Install RH & LH Side Roof Rack Brackets.

(a) Remove adhesive backing & install mastic washers on bottom of bracket holes. (Fig.3-1)

(b) Install the bracket as shown. (Fig. 3-1)



(c) Install 2 short torx head screws tighten to 13.3 N.m (117.7 lbf-in). (Fig. 3-1)



(d) Using an X-Acto knife or deburring tool, carefully remove all seal material in the REAR 6 HOLES (3 RH & 3 LH) so that the weld nut is visible and no seal material is down near the threads. (Fig. 2-1)



(e) Ensure AT LEAST 5 MINUTES has elapsed since front bracket screws were tightened before proceeding to the next step.



(f) RE-TORQUE the front bracket screws to 13.3 N.m (117.7 lbf-in). (Fig. 3-1)

### 4. Install RH Side Roof Rack.

(a) RH side roof rack does not have the crossbar pre-assembled. Remove adhesive backing and install 3 mastic washers onto the bottom surface mounting posts prior to installing to roof. (Fig. 4-1)

(b) Align assembly so that the pad nose fits into the ditch and is snug against the front window lace. (Fig. 4-1)

(c) Visually align the yellow clip at the front above the hole in the bracket. Using the palm of your hand, strike firmly to seat in place. (Fig. 4-1)

(d) Hand start the 3 long torx head screws into roof rack along roof ditch. (Fig. 4-2)



(e) Using an awl, center the bracket hole below the access hole in the roof rail. Install first screw and tighten. Install second bracket screw. Torque the 2 short torx head screws to 5.6 N.m (50 lbf-in). (Fig. 4-3)

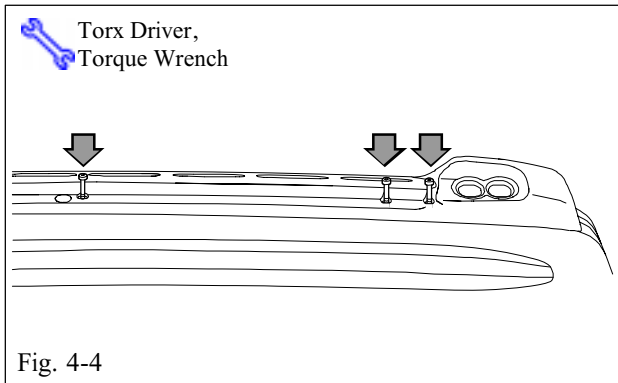

-  (f) Torque the 3 long torx head screws to 13.3 N.m (117.7 lbf-in) (Fig. 4-4)

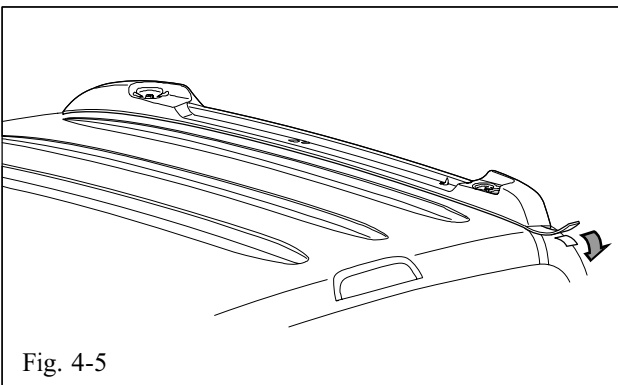

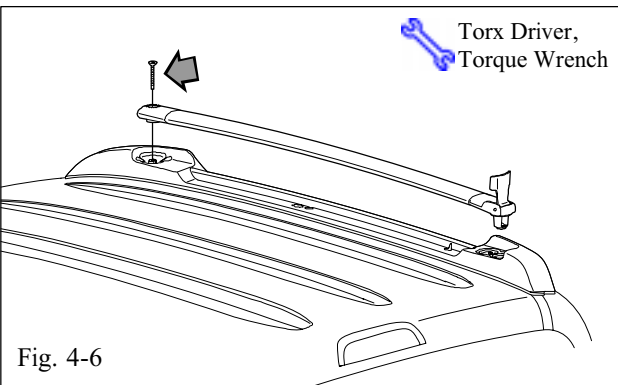

- (g) Align the stub on the rear of the pad with the roof ditch, once aligned, remove tape backing and press down firmly. Tuck the stub under the rear window lace. (Fig. 4-5)

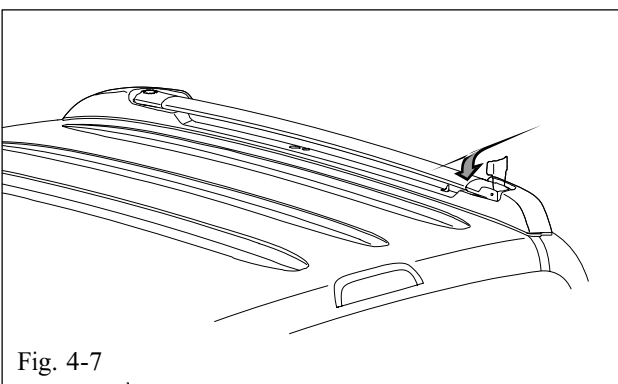

- (h) Install crossbar assembly to roof rack. (Fig. 4-6)

-  (i) Install torx head pivot bolt torque to 5.6 N.m (50 lbf-in) (Fig. 4-6)



-  (j) Ensure crossbar is secure by lowering lever. (Fig. 4-7)

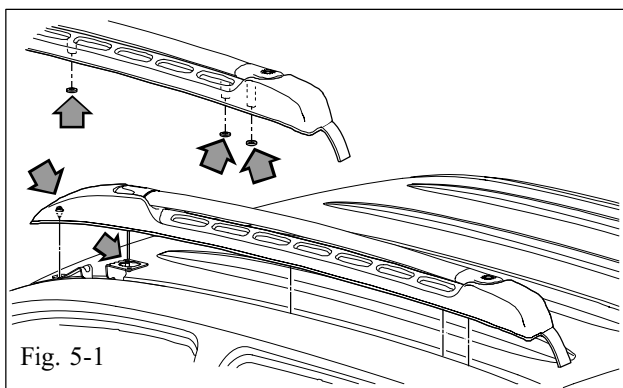

Fig. 5-1

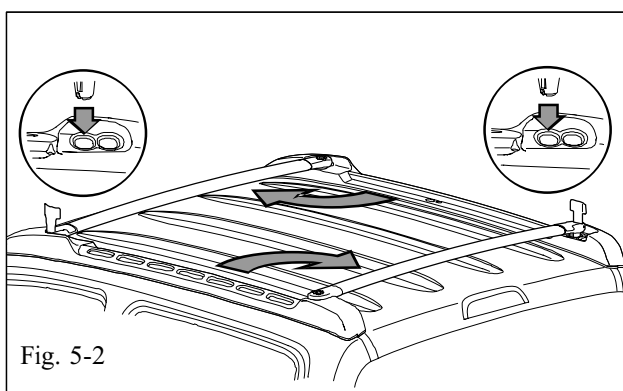

Fig. 5-2

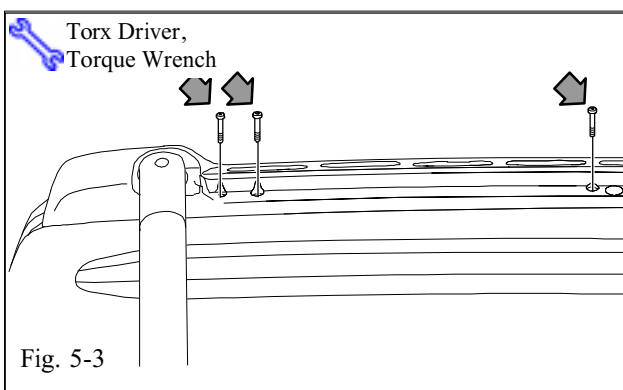

Fig. 5-3

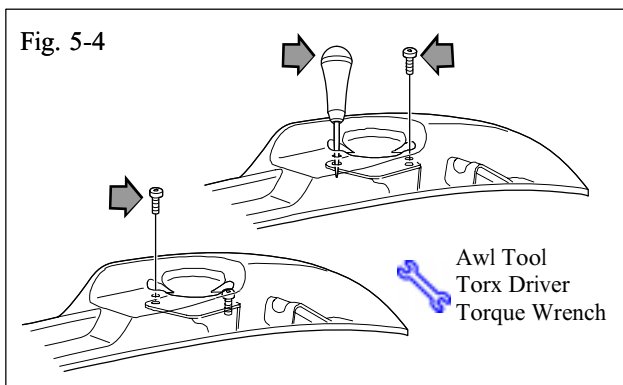



Fig. 5-4

**5. Install LH Side Roof Rack.**

- (a) LH side roof rack has crossbar pre-assembled. Remove adhesive backing and install 3 mastic washers onto the bottom surface mounting posts prior to installing to roof. (Fig. 5-1)
- (b) Align assembly so that the pad nose fits into the ditch and snug against the front window lace. (Fig. 5-1)
- (c) Visually align the yellow clip at the front above the hole in the bracket. Using the palm of your hand, strike firmly to seat in place. (Fig. 5-1)
- (d) Lift LH & RH crossbar levers into open position and rotate crossbars so they rest on the base rails as shown, do not latch. (Fig. 5-2)
- (e) Hand start the 3 long torx head screws into roof rack along roof ditch. (Fig. 5-3)
- (f) Rotate crossbar from LH front rail to access front screw holes.
-  (g) Using an awl, center the bracket hole below the access hole in the roof rail. Install first screw and tighten. Install second bracket screw. Torque the 2 short torx head screws to 5.6 N.m (50 lbf-in). (Fig. 5-4)
-  (h) Torque the 3 long torx head screws into the roof rack along roof ditch to 13.3 N.m (117.7 lbf-in) (Fig. 5-3)

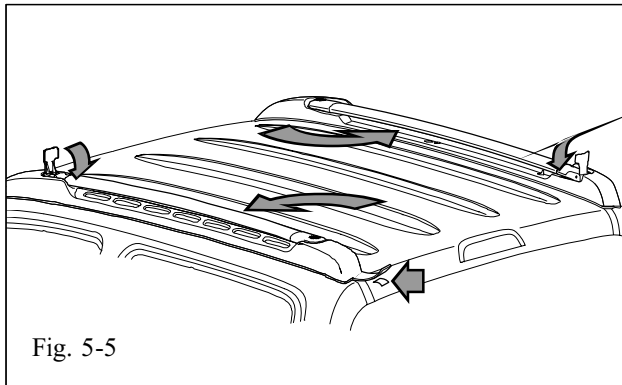



Fig. 5-5

- (i) Align the stub on the rear of the pad with the roof ditch, once aligned, remove tape backing and press down firmly. Tuck the stub under the rear window lace. (Fig. 5-5)
- (j) Reposition crossbars into base rails and close levers as shown. (Fig. 5-5)
-  (k) Staple 3x5 roof rack caution card into inside of rear cover of the owner's manual.

Checklist - these points **MUST** be checked to ensure a quality installation.

<u>Check:</u>	<u>Look For:</u>
<p><u>Accessory Function Checks</u></p> <ul style="list-style-type: none"><li><input type="checkbox"/> Ensure crossbars will install and lock into the deployed (cross-car) position</li><li><input type="checkbox"/> Crossbars should be securely locked into base rails (stowed) for shipment</li></ul>	<p>Crossbars to lock into the deployed (cross-car) position securely</p> <p>Securely locked into base rails (stowed)</p>
<p><u>Vehicle Function Checks</u></p> <ul style="list-style-type: none"><li><input type="checkbox"/> None Required</li></ul>	