

Part Number: PT347-35051 (Short Bed)
PT347-35052 (Long Bed)

NOTE: Part number of this accessory may not be the same as the part number shown.

Kit Contents

Item #	Quantity Reqd.	Description
1	1	Bed Net
2	1	Installation Instructions
3	1	Hardware Bag

Hardware Bag Contents

Item #	Quantity Reqd.	Description
1	2	D-Rings

Additional Items Required For Installation

Item #	Quantity Reqd.	Description

Conflicts

--

Recommended Tools

Personal & Vehicle Protection	Notes
None	
Special Tools	Notes
None	
Installation Tools	Notes
Socket	10 mm
Torque Wrench	0 - 50 lbf-in.
Special Chemicals	Notes
None	

General Applicability

--

Recommended Sequence of Application

Item #	Accessory

*Mandatory

Vehicle Service Parts (may be required for reassembly)

Item #	Quantity Reqd.	Description

Legend



STOP: Damage to the vehicle may occur. Do not proceed until process has been complied with.



OPERATOR SAFETY: Use caution to avoid risk of injury.



CAUTION: A process that must be carefully observed in order to reduce the risk of damage to the accessory/vehicle and to ensure a quality installation.



TOOLS & EQUIPMENT: Used in Figures calls out the specific tools and equipment recommended for this process.

Care must be taken when installing this accessory to ensure damage does not occur to the vehicle. The installation of this accessory should follow approved guidelines to ensure a quality installation.

These guidelines can be found in the "Accessory Installation Practices" document.

This document covers such items as:-

- Vehicle Protection (use of covers and blankets, cleaning chemicals, etc.).
- Safety (eye protection, rechecking torque procedure, etc.).
- Vehicle Disassembly/Reassembly (panel removal, part storage, etc.).
- Electrical Component Disassembly/Reassembly (battery disconnection, connector removal, etc.).

Please see your Toyota dealer for a copy of this document.

1. Install Hardware.

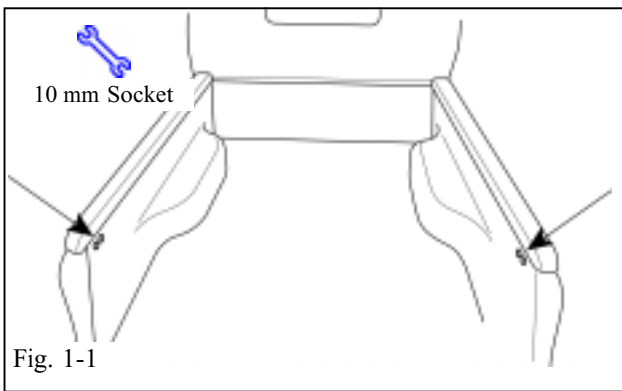

(a) Locate the anchor points at the rear of the vehicle (Fig 1-1).





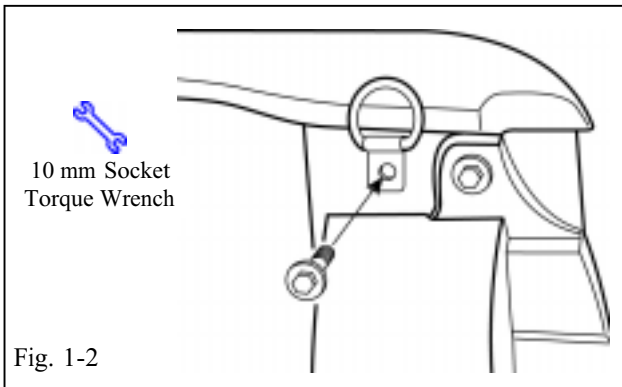

(b) Using a 10 mm Hex socket wrench, remove forward bolt, position D-ring (flat side against bed) over hole as shown, re-fasten bolt into hole over D-ring (Fig. 1-2).

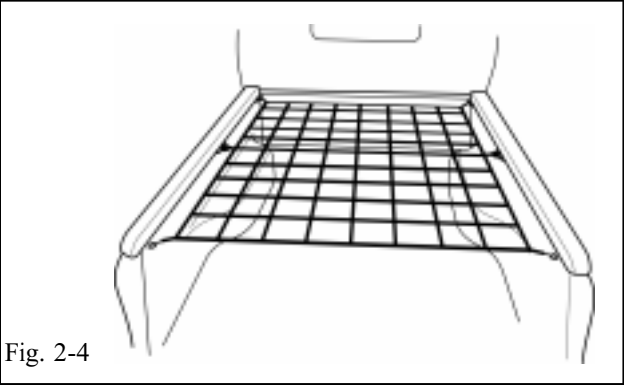
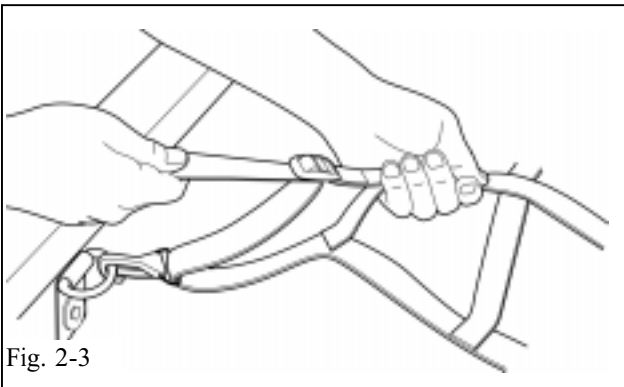
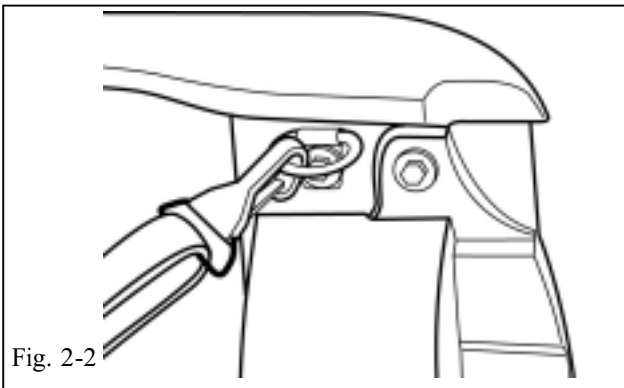
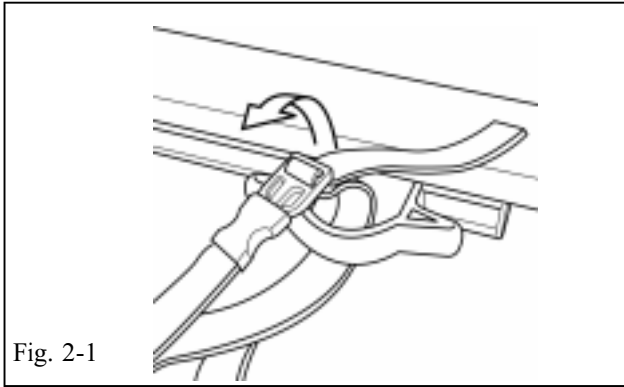
(c) Tighten bolt to 3.7 lbf-ft (44 lbf-in).





2. Install Net.

-  (a) Lay the net in the bed with the hooks near the tailgate.
- (b) Slide the front cleats to the forward position and secure.
- (c) Insert the ends of the net through the front cleats and fasten the clips as shown (Fig. 2-1).
- (d) Position the other cleats at the center of the bed rail and secure.
-  (e) Insert the ends of the net through the middle cleats and fasten the clips as shown (Fig. 2-1).
- (f) Attach the hooks to the D-rings at the rear of the bed as shown (Fig 2-2).
-  (g) Cinch the net taut at all six attachment locations as shown (Fig. 2-3).
-  (h) Confirm completed assembly (Fig. 2-4).

NOTE: Adjust cleats and straps as necessary to accommodate various size loads.

Checklist - these points **MUST** be checked to ensure a quality installation.

Check:

Accessory Function Checks

Confirm that the net is attached properly to the anchor points in the vehicle.

 Confirm that the hardware is attached properly to the vehicle.

Look For:

Make sure net straps have been inserted from the underside of the cleat and the snap clips have been securely fastened. Make sure hooks have been fastened securely to the D-rings.

Make sure bolts have been fastened to the vehicle over the D-rings with the D-ring in the upright position. Make sure the bolts are fastened tightly over the D-rings.