

Preparation

**Part Number:**

**PTS09-35060 (B-CAB REGULAR BED)**

**PTS09-35061 (C-CAB REGULAR BED)**

**PTS09-35062 (D-CAB REGULAR BED)**

**PTS09-35063 (D-CAB SHORT BED)**

**NOTE:** Part number of this accessory may not be the same as the part number shown.

**Kit Contents**

Item #	Quantity Req'd.	Description
1	1	Right Side Step
2	1	Left Side Step
3	1	Hardware Bag

**General Applicability**

2005MY Tacoma's
-----------------

**Hardware Bag Contents**

Item #	Quantity Req'd.	Description
1	12 (C & D Cab)	8mm x 30mm x 1.25mm Bolts
2	12 (C & D Cab)	Lock Washers
3	6 (C & D Cab)	Round Flat Washers
4	6 (C & D Cab)	Flat End Washers
5	8 (B Cab)	8mm x 30mm x 1.25mm Bolts
6	8 (B Cab)	Lock Washers
7	4 (B Cab)	Round Flat Washers
8	4 (B Cab)	Flat End Washers
9	1	Installation Instructions

**Recommended Sequence of Application**

Item #	Accessory

\*Mandatory

**Vehicle Service Parts** (may be required for reassembly)

Item #	Quantity Req'd.	Description
1		

**Additional Items Required For Installation**

Item #	Quantity Req'd.	Description
1		





**Conflicts**

Genuine Running Boards: C-CAB PN: PT212-35052 D-CAB PN: PT212-35054
---

**Recommended Tools**

<b>Personal &amp; Vehicle Protection</b>	<b>Notes</b>
Eye Protection	
<b>Special Tools</b>	<b>Notes</b>
None	
<b>Installation Tools</b>	<b>Notes</b>
Socket/Ratchet	13mm
Torque Wrench	14.4 lbf·ft (19 N.m)
Tape Measure	
Screwdriver	Flat Head
<b>Special Chemicals</b>	<b>Notes</b>

**Legend**

	<b>STOP:</b> Damage to the vehicle may occur. Do not proceed until process has been complied with.
	<b>OPERATOR SAFETY:</b> Use caution to avoid risk of injury.
	<b>CAUTION:</b> A process that must be carefully observed in order to reduce the risk of damage to the accessory/vehicle and to ensure a quality installation.
	<b>TOOLS &amp; EQUIPMENT:</b> Used in Figures calls out the specific tools and equipment recommended for this process.
	<b>REVISION MARK:</b> This mark highlights a change in installation with respect to previous issue.

Care must be taken when installing this accessory to ensure damage does not occur to the vehicle. The installation of this accessory should follow approved guidelines to ensure a quality installation.

These guidelines can be found in the "Accessory Installation Practices" document.

This document covers such items as:-

- Vehicle Protection (use of covers and blankets, cleaning chemicals, etc.).
- Safety (eye protection, rechecking torque procedure, etc.).
- Vehicle Disassembly/Reassembly (panel removal, part storage, etc.).
- Electrical Component Disassembly/Reassembly (battery disconnection, connector removal, etc.).

Please see your Toyota dealer for a copy of this document.

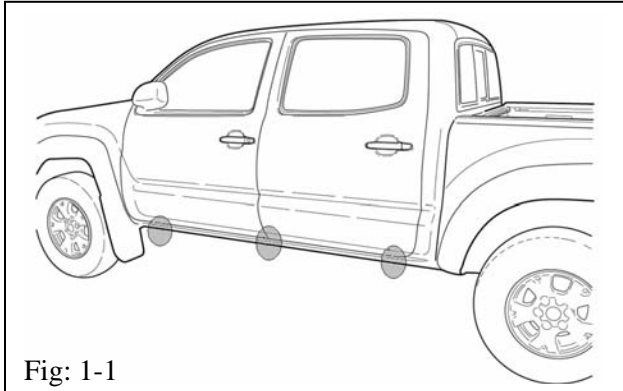

Fig: 1-1

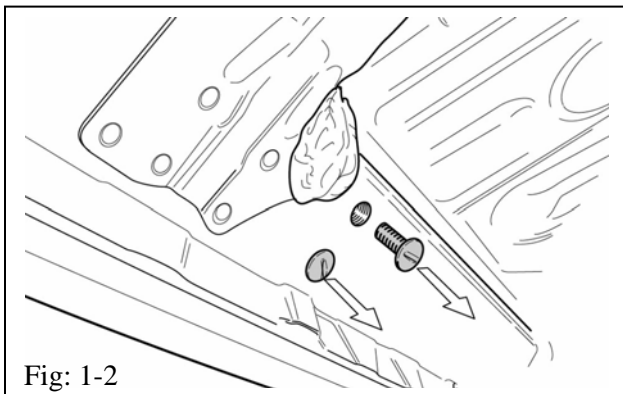

Fig: 1-2

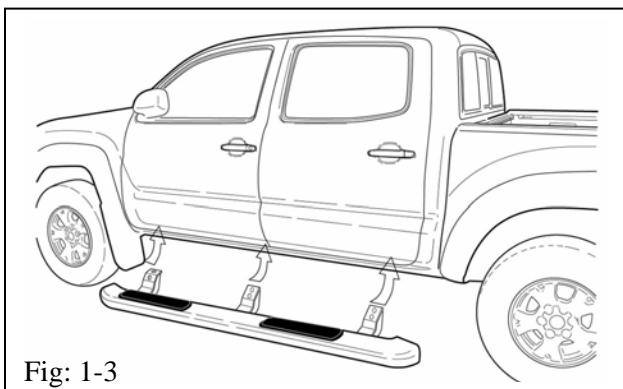

Fig: 1-3

**1. Install Driver Side Step.**

- (a) Remove the six (6) (for C & D-cab) or the four (4) (for B Cab) plastic screws located in the side step mounting holes under the vehicle and discard. (Fig. 1-1 & 1-2)
- (b) Place the side step under the vehicle and line-up the mounting holes on the brackets with the mounting holes on the vehicle. (Fig. 1-3)
- (c) By hand, place three (3) flange bolts with one (1) lock washers and one (1) round flat washer per bolt into the mounting holes that are towards the inside of the vehicle and hand tighten. (Fig. 1-4)
- (d) By hand, place three (3) flange bolts with one (1) lock washers and one (1) flat end washer per bolt into the mounting holes that are towards the outside of the vehicle and hand tighten. **Ensure that the flat end of the washer is parallel to the bend line of the bracket. (Fig. 1-4)**
- (e) Align the tube so that it is centered on the vehicle (Fig. 1-5). The bolts that are pre-installed that hold the brackets to the tube are only hand tight to allow for easy loosening if required to aide alignment.
- (f) Tighten and torque all six (6) or four (4) flange bolts on vehicle to 14.4 ft-lbs +/- 3.6 ft-lbs. (19Nm +/- 4.8Nm) (Fig: 1-4)

- (g) Tighten and torque all six (6) or four (4) flange bolts on tube to 14.4 ft-lbs +/- 3.6 ft-lbs. (19Nm +/- 4.8Nm) (Fig: 1-4)

**2. Install Passenger Side Step.**

- (a) Repeat same process as Driver side.

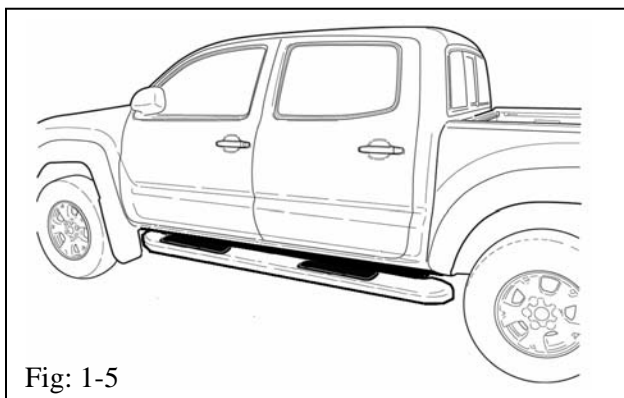
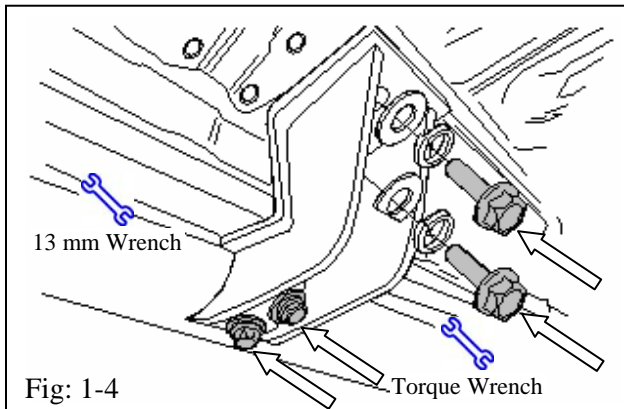

**TOYOTA TACOMA 2005 - TUBE STEPS**

Checklist - these points **MUST** be checked to ensure a quality installation.

Check:

Look For:

Accessory Function Checks

- Tube alignment
  
- Installation torque with torque wrench and 13mm socket

Tubes should be aligned so that they are centered on the vehicle

All Fasteners have been installed at a torque of 14.4 ft-lbs +/- 3.6 ft-lbs.

Vehicle Function Checks