



TECHNICAL SERVICE BULLETIN

REF.: ACCESSORIES
NO.: AC91-003
DATE: DECEMBER 20, 1991
MODEL: SW

1992 MR2 THEFT DETERRENT SYSTEM ENHANCEMENT ("TDSE") FITTING KIT

Page 1 of 4

On 1992 MR2s equipped with "TDSE," if the tail lights do not flash when the alarm is triggered, then one wire was omitted from the TDSE fitting kit by the supplier (Kit #00398-17910).

Upon customer complaint, contact Fujitsu Ten Corporation of America at the number listed below:

**Fujitsu Ten Corporation of America
1-800-237-5413
Monday thru Friday
8:30 am to 5:00 pm PST**

A TDSE repair kit containing a replacement wire and installation instructions will be forwarded via over-night mail. The following is a copy of the installation procedures.

PREPARATION OF VEHICLE:

1. Verify security status of the audio unit. Obtain the security code from the customer if a code has been set.
2. Record all preset stations of the audio unit.
3. Tilt the steering wheel to the lowest and most extended position.
4. Disconnect the negative (-) terminal of the battery. Wait at least 20 seconds before disconnecting any electrical component.

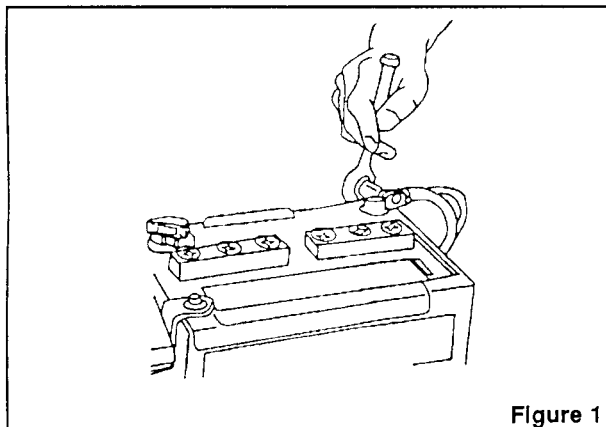

Figure 1

1. DISCONNECT THE NEGATIVE BATTERY LEAD

- a) Using a 10-mm socket, loosen and remove the negative lead from the battery as shown in Figure 1.

1992 MR2 "TDSE" FITTING KIT (CONT'D)

AC91-003 2/4

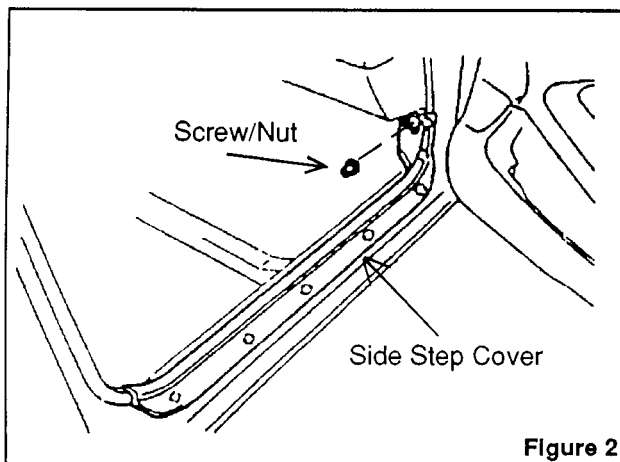

2. REMOVE THE SCREW/NUT SECURING THE PASSENGER SIDE COWL COVER

- Remove the passenger side step/cowl cover by gently prying loose as shown in Figure 2.

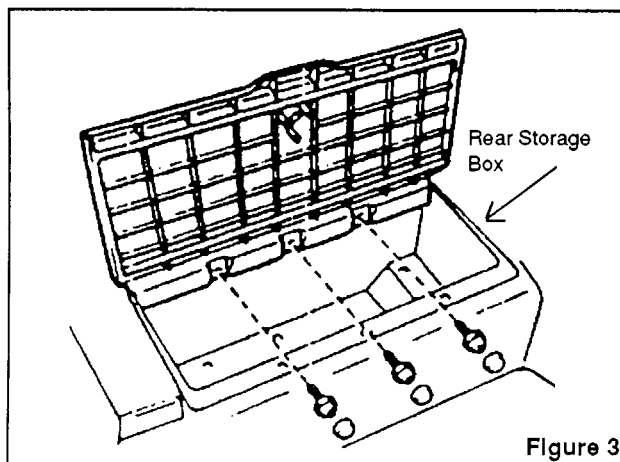

3. PRY LOOSE THE CAPS COVERING THE SCREWS SECURING THE PASSENGER SIDE REAR STORAGE BOX COVER

- Using a Phillips screwdriver, remove the three screws securing the cover. **Do not remove the cover separately.**

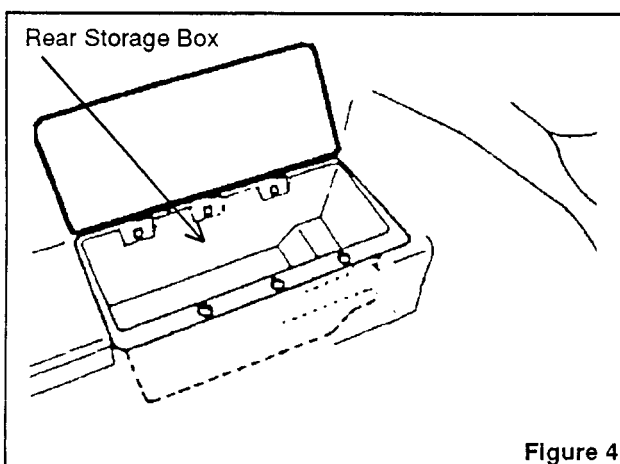

4. REMOVE THE THREE RETAINERS SECURING THE PASSENGER SIDE REAR STORAGE BOX

- Remove the box and lid as shown in Figure 4.

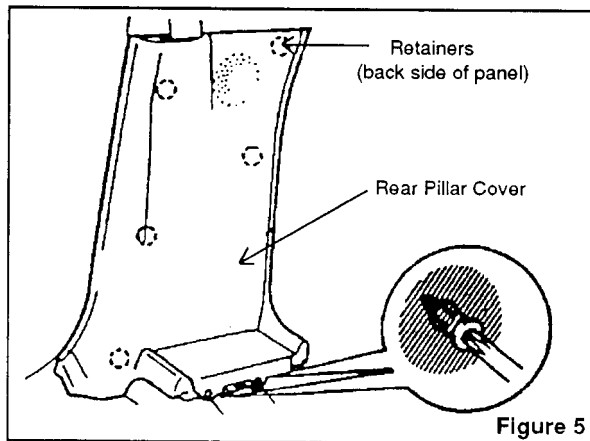

Figure 5

5. REMOVE THE CENTER PINS

- a) Push the center pins of the two retainers securing the bottom edge of the passenger side rear pillar cover, then pry them out as shown in Figure 5.

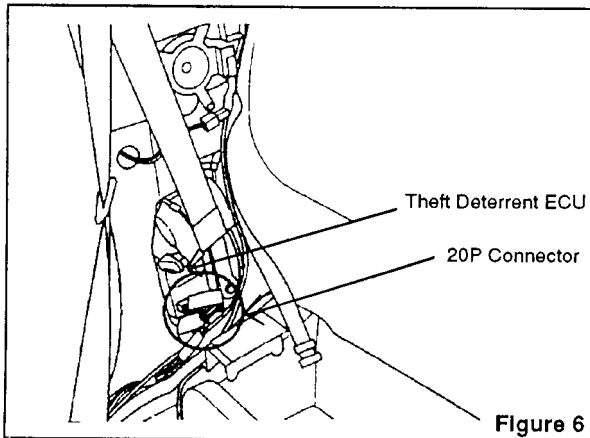

Figure 6

6. DISCONNECT THE FITTING KIT'S THEFT DETERRENT MALE AND FEMALE 20P CONNECTORS

- a) Disconnect the Fitting Kit female 20P connector from the theft deterrent ECU.
- b) Disconnect the theft deterrent female 20P connector from the Fitting Kit male 20P connector.

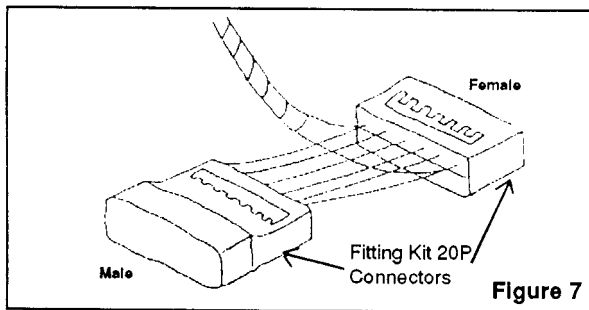

Figure 7

7. ADJUST THE FITTING KIT TABS

- a) Turn the Fitting Kit theft deterrent male and female 20P connectors so that the tabs are facing down as shown in Figure 7.

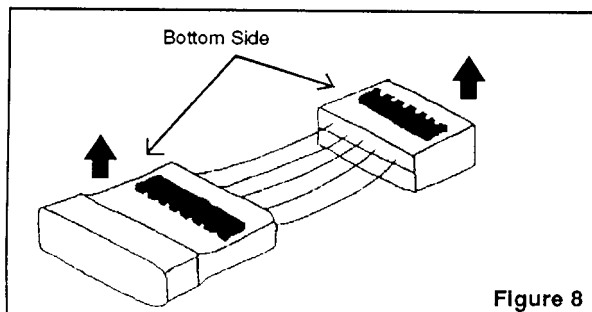

Figure 8

8. UNLOCK THE PIN CLAMPS ON THE FITTING KIT THEFT DETERRENT MALE AND FEMALE 20P CONNECTORS

- a) Using a small, flat blade screwdriver, lift up and unlock the pin clamps on the theft deterrent male and female 20P connectors as shown Figure 8.

1992 MR2 THEFT DETERRENT SYSTEM ENHANCEMENT ("TDSE") FITTING KIT (CONT'D)

AC91-003 4/4

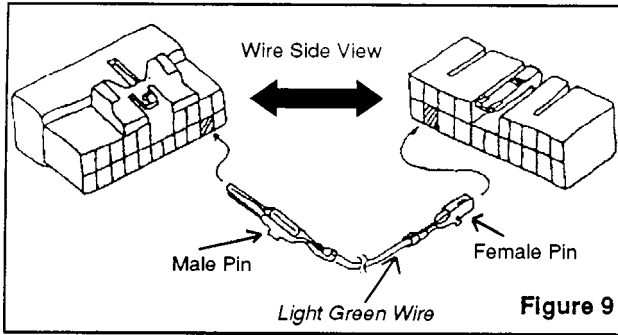

9. INSERT THE ADDITIONAL **LIGHT GREEN WIRE** INTO THE FITTING KIT THEFT DETERRENT MALE AND FEMALE 20P CONNECTORS

- Turn the connectors over so that the tabs are on top, and wire is facing you as shown in Figure 9.
- Insert the **light green** wire's male pin into the second space from the right on the bottom row of the male connector.
- Insert the **light green** wire's female pin into the second space from the left on the bottom row of the female connector.

Note: The pin location in number 19 on both connectors.

10. LOCK THE PIN CLAMPS ON THE FITTING KIT THEFT DETERRENT MALE AND FEMALE 20P CONNECTORS

- Press down the clamp until a "click" is heard.

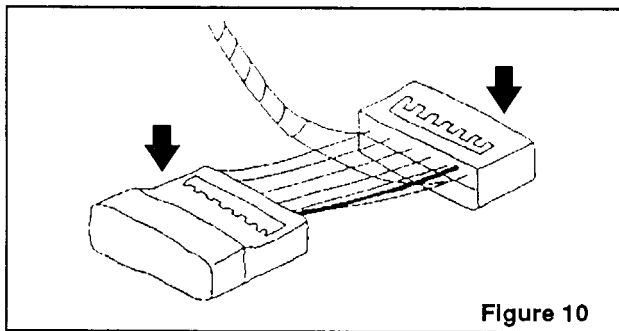

11. RECONNECT THE FITTING KIT 20P CONNECTORS TO THE THEFT DETERRENT ECU AND ECU CONNECTOR

- Insert the Fitting Kit female 20P connector into the theft deterrent ECU.
- Insert the theft deterrent female 20P connector into the Fitting Kit male 20P connector.

12. RECONNECT THE BATTERY, VERIFY FUNCTIONS, AND REPLACE THE PREVIOUSLY REMOVED PANELS.

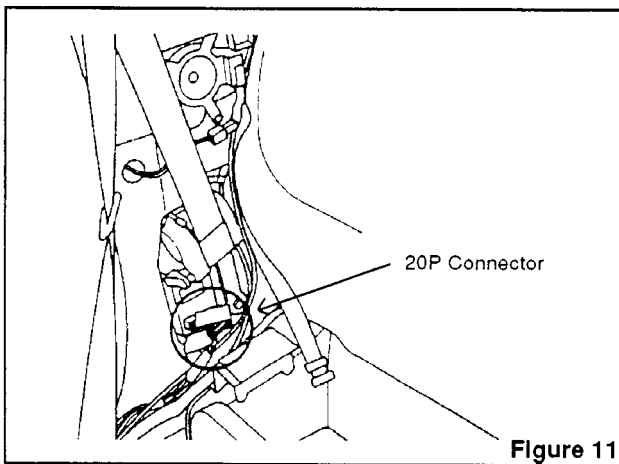

FINAL INSPECTION:

- Set the audio security system
- Set all audio preset stations